

BIPOLAR ANALOG INTEGRATED CIRCUIT

μ PC1270H

30-50 W POWER AMPLIFIER DRIVER

DESCRIPTION

μ PC1270H is designed for use with a Hi-Fi power amplifier driver. It is composed of a differential amplifier, a predriver, a driver and protection circuit.

It is in a 12 pin small power SIP. (Single In Line)

FEATURES

- Excellent Low Distortion.
0.002 % TYP. ($V_{CC} = \pm 36$ V, $f = 1$ kHz, $A_v = 30$ dB, $P_O = 30$ W, $R_L = 8$ Ohms)
0.006 % TYP. ($V_{CC} = \pm 36$ V, $f = 20$ kHz, $A_v = 30$ dB, $P_O = 30$ W, $R_L = 8$ Ohms)
- Wide Frequency Band.
900 kHz TYP. (-3 dB)
- Wide Power Band Width.
90 kHz TYP. ($P_O = 25$ W, T.H.D. = 0.1 %)
- Excellent Low POP ON/OFF Noise.

BLOCK DIAGRAM

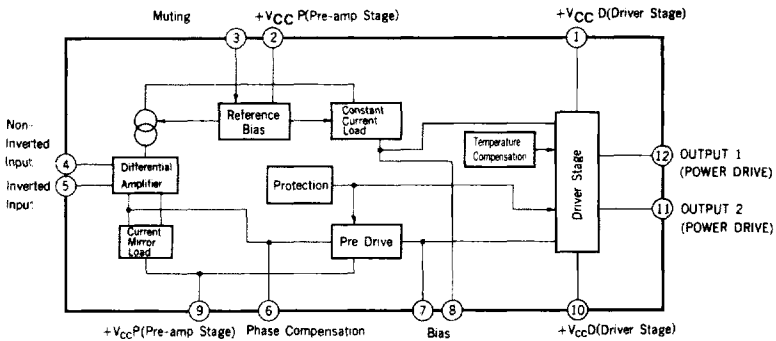

NOTE: The protection circuit is for this IC and cannot protect external Power Transistors. Thus, design a $P_O T_r$ protection circuit besides.

ABSOLUTE MAXIMUM RATINGS ($T_a = 25\text{ }^\circ\text{C}$)

Supply Voltage (Quiescent)	V_{CC1}	± 50	V
Supply Voltage (Operational)	V_{CC2}	± 45	V
Quiescent Circuit Current	$I_{CC}(\text{peak})$	200	mA
Allowable Package Dissipation	P_D	4.1	W
Operational Temperature	T_{opt}	-20 to +75	$^\circ\text{C}$
Storage Temperature	T_{stg}	-40 to +150	$^\circ\text{C}$

RECOMMENDED OPERATING CONDITION

Supply Voltage (Operational)	$V_{CC} = \pm 18$ to ± 36 V at MAX. Power Output
Input Bias Resistance	$R_{IN} = 1$ to 50 to 100 kohms
Power Transistor h_{FE}	$h_{FE} = 50$ at MAX. Power Output
Closed Loop Voltage Gain	$A_v = 26$ to 30 dB

ELECTRICAL CHARACTERISTICS ($V_{CC} = \pm 36$ V, $A_v = 30$ dB, Use Standard Test Circuit, $T_a = 25\text{ }^\circ\text{C}$)

CHARACTERISTIC	SYMBOL	MIN.	TYP.	MAX.	UNIT	CONDITION
Output Offset Voltage	V_{OFF}		± 5	± 100	mV	SEE TEST CIRCUIT 1
Quiescent Circuit Current	I_{CC}		20	40	mA	$V_{IN} = 0$
Maximum Output Voltage	V_{OM}	20	23		V	T.H.D. = 0.05 % $f = 20$ to 20 kHz
Open Loop Voltage Gain	A_{vo}	80	95		dB	$V_O = 1.5$ V, $f = 1$ kHz
Output Noise Voltage	V_{NO}		0.07	0.14	mV	$R_G = 10$ kohms
Power Band Width	P.B.W.		900		kHz	$V_O = 1.5$ V, -3dB
Supply Voltage Rejection Ratio	S.V.R.	55	70		dB	$R_G = 2$ kohms, $f = 100$ Hz
Output Offset Voltage (Mute)	$V_{OFF}(\text{Mute})$			± 50	mV	$V_{CC} = \pm 50$ V, TEST CIRCUIT 7

12 PIN SIP (Unit : mm)

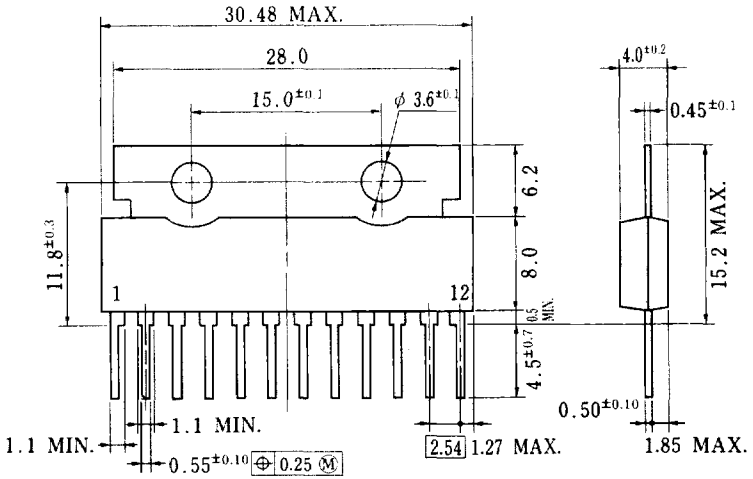

P12HP-254B1

PIN CONNECTION DIAGRAM

PIN NO.	PIN CONNECTION
1	+V _{CCD} (for Driver)
2	+V _{CCP} (for Preamp)
3	MUTING
4	INPUT
5	NFB
6	PHASE COMP
7	BIAS
8	BIAS
9	-V _{CCP} (for Preamp)
10	-V _{CCD} (for Driver)
11	LOWER OUTPUT
12	UPPER OUTPUT

μ PC1270H

TEST CIRCUIT 1 (V_{OFF})

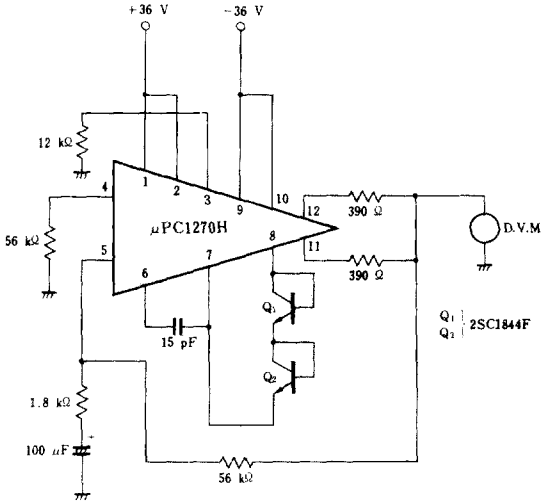

TEST CIRCUIT 2 (I_{CC})

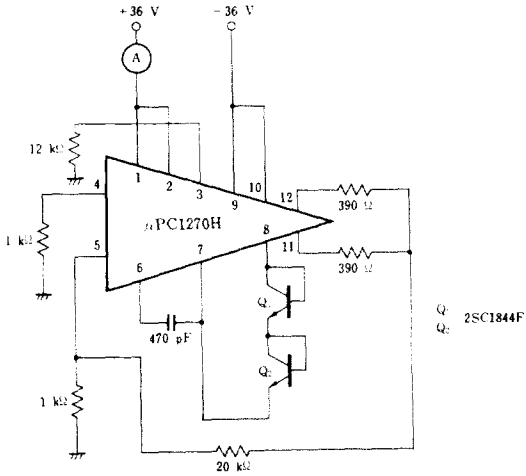

TEST CIRCUIT 3 (V_{OM})

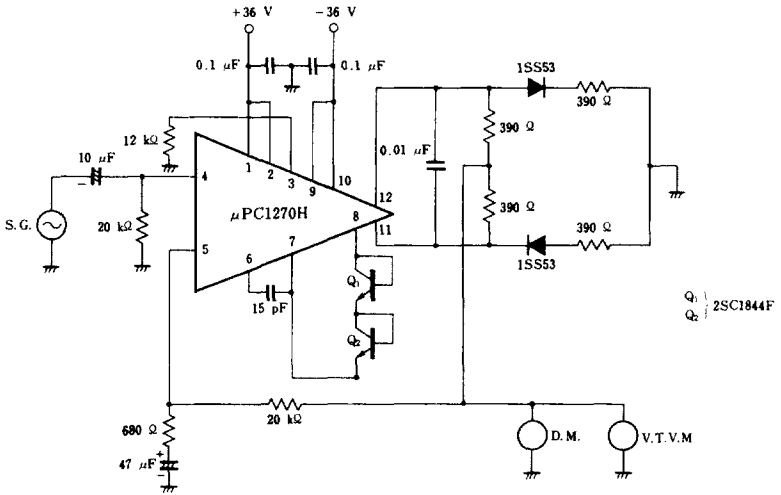

TEST CIRCUIT 4 (A_{VO})

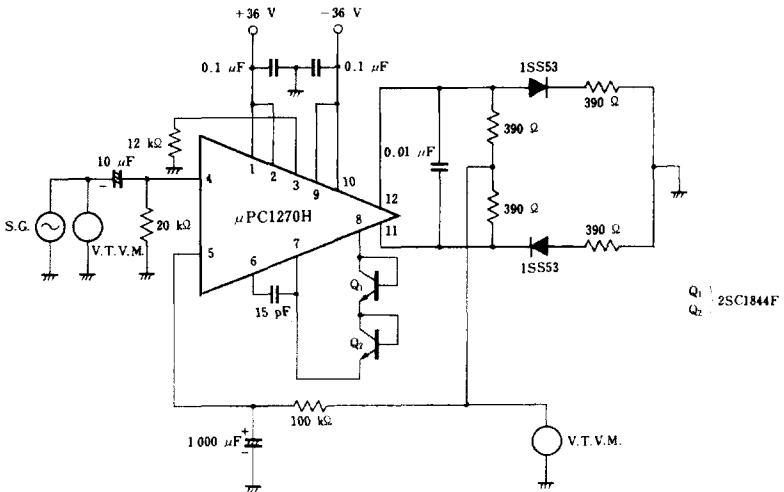

μ PC1270H

TEST CIRCUIT 5 (V_{NO})

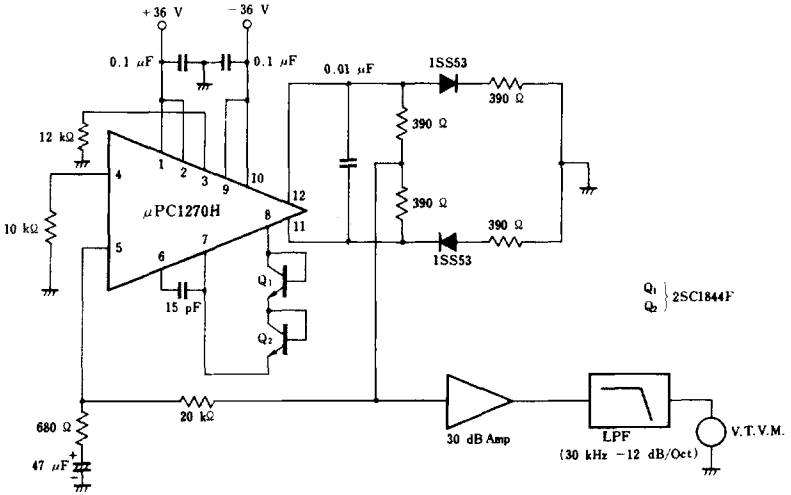

TEST CIRCUIT 6 (S.V.R.)

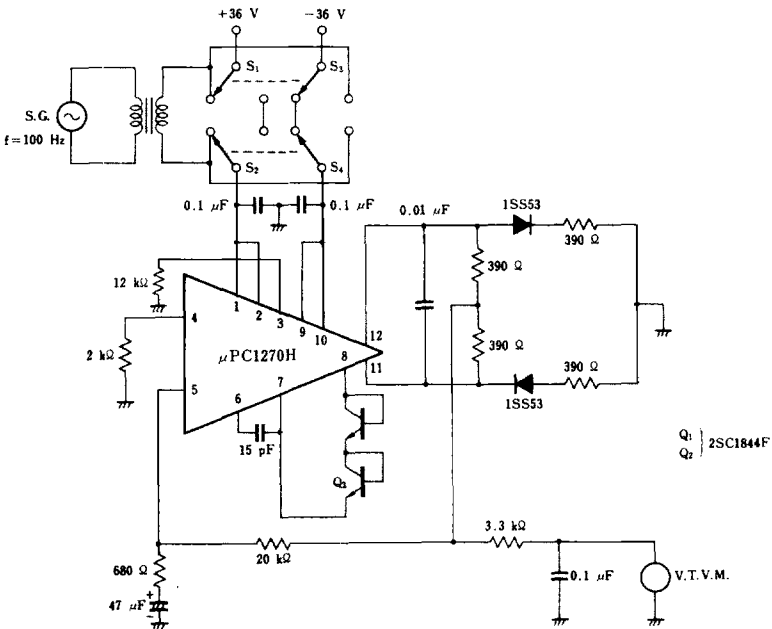

TEST CIRCUIT 7 ($V_{OFF(MUTE)}$)

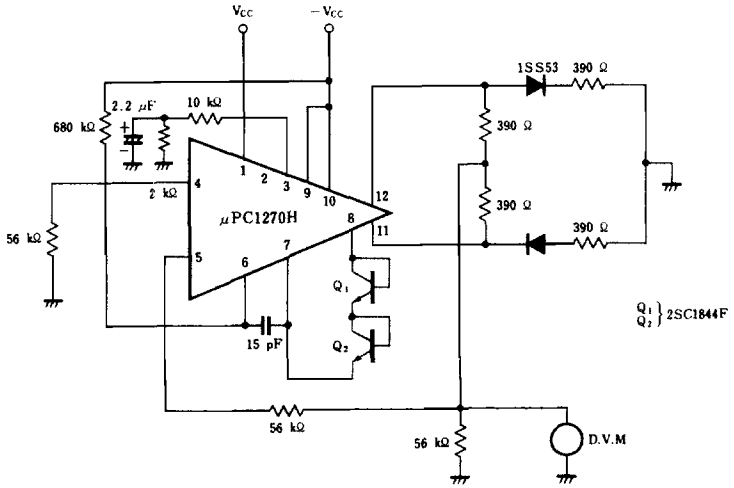

TYPICAL CHARACTERISTICS (T_a = 25°C)

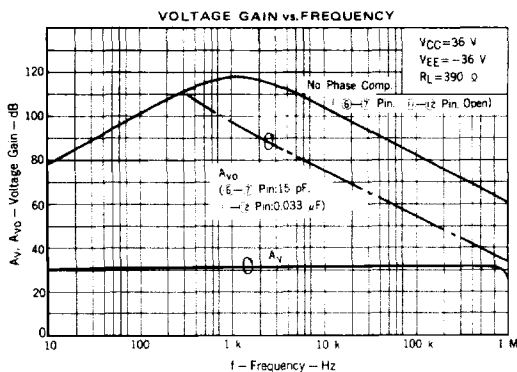
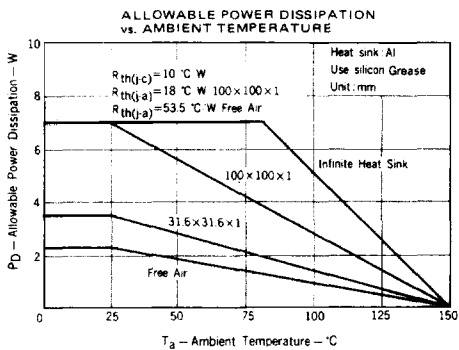

**OPEN LOOP VOLTAGE GAIN
SUPPLY VOLTAGE REJECTION RATIO
OUTPUT NOISE VOLTAGE
CIRCUIT CURRENT
OUTPUT OFFSET VOLTAGE
vs. SUPPLY VOLTAGE**

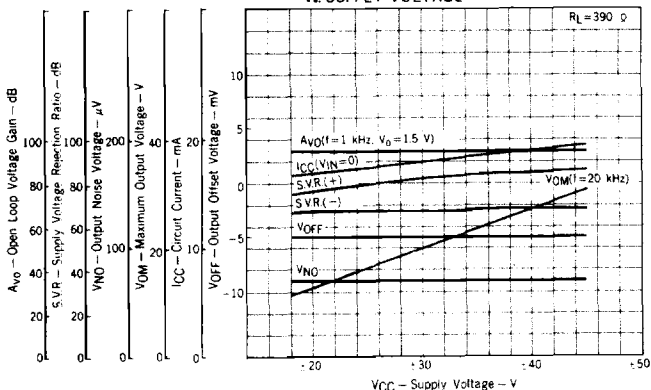

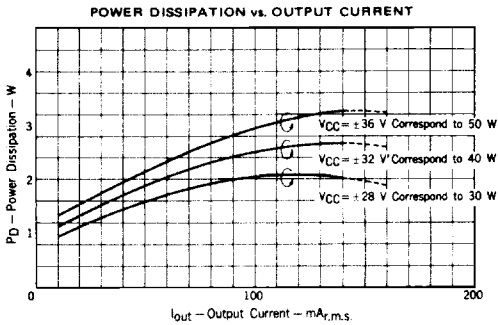
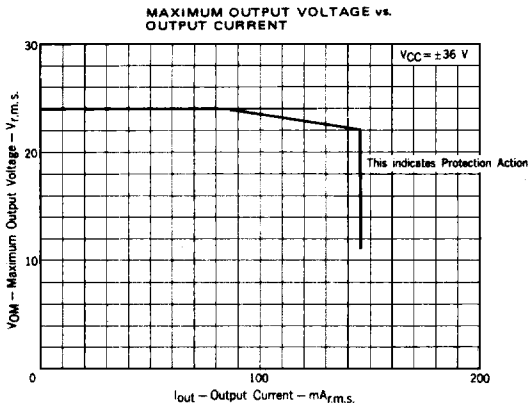
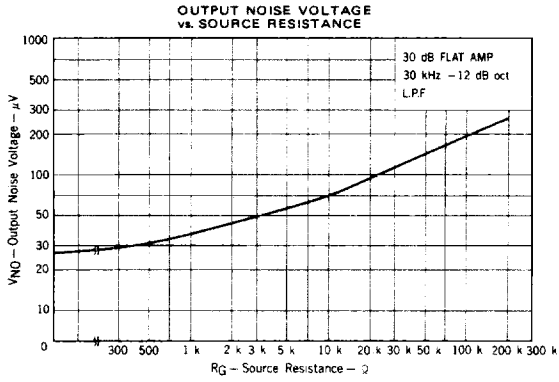

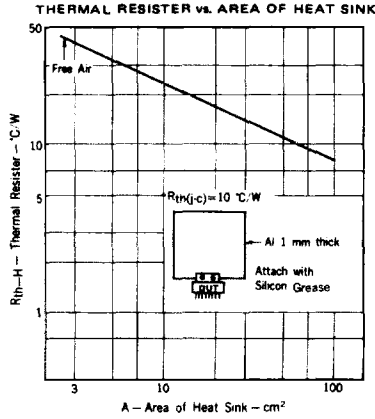

APPLICATION CIRCUIT-1

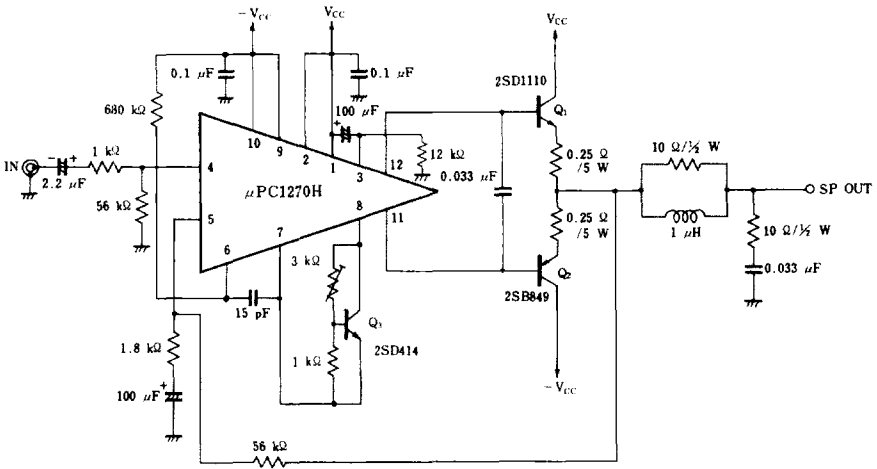

μPC1270H APPLICATION CIRCUIT-2 (no Relay)

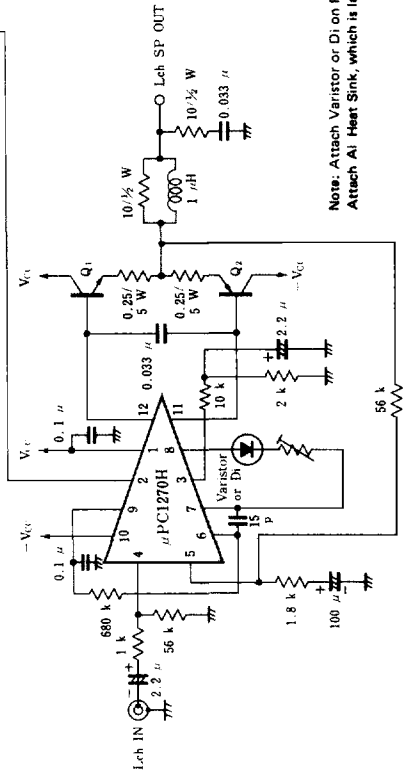
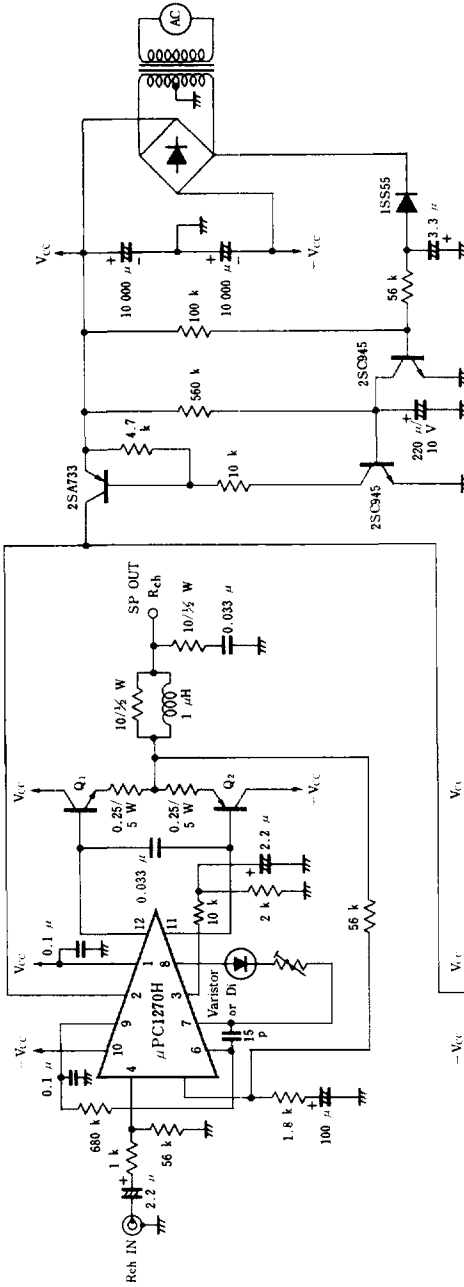

Stage of Po Transistor

P ₀	25 ~ 40 W	45 ~ 55 W
Q ₁	2SD1288	2SD1289
Q ₂	2SB965	2SB966

Note: Attach Varistor or Di on P₀ Tr. Heat Sink. Attach Al. Heat Sink, which is larger than 60 mm X 60 mm X 1 mm, with μPC1275H.

μPC1270H/μPC1237H/MP-80 EVALUATION CIRCUIT

Unit : R : Ω
C : F

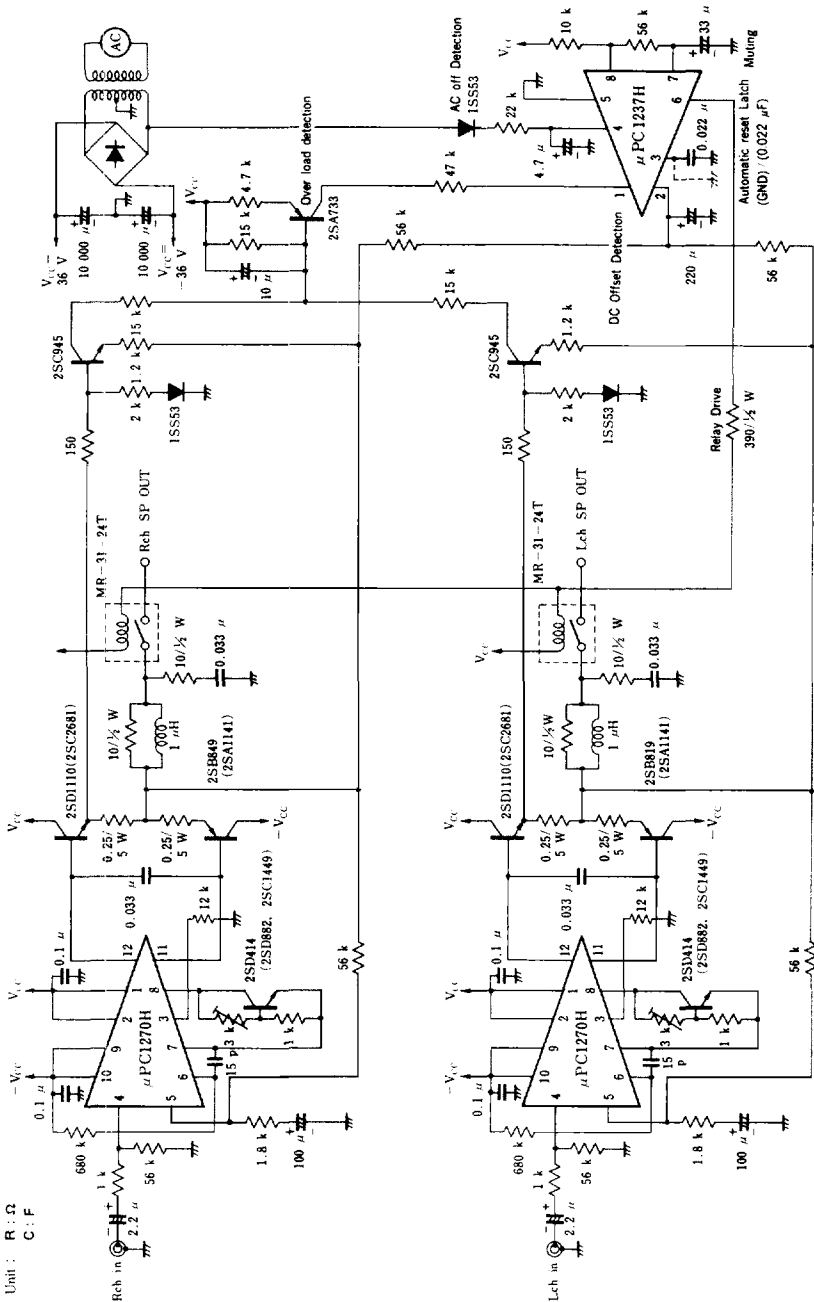

Note: Attach 2SD414 on P_{OT} Heat Sink.
Attach AI Heat Sink, which is larger than 60 mm X 60 mm X 1 mm, with μPC1270H.

μPC1270H/μPC1224H/MP-80 (ZSC849, 2SD1110 or 2SA2681, ZSC1141) Evaluation Circuit Board Component Arrangement

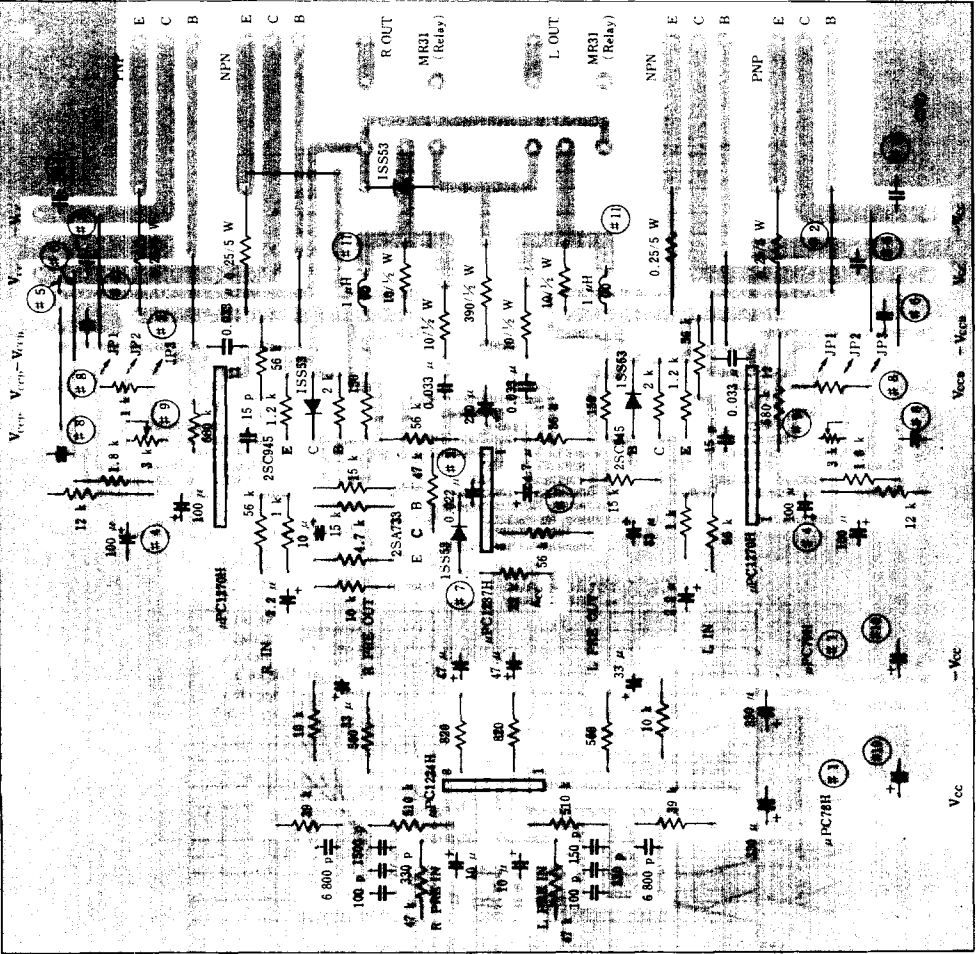

Note:

- #1 These terminals are for 3-terminals regulators (μPC7818H, μPC7918H) as a μPC1224H power supply.
- #2 These terminals are for JP-lines to a temperature Compensation transistor (2SD414 or others).
- #3 Use 0.02 μF capacitance in case of using μPC1237H at latching function, while connect each other at automatic resetting.
- #4 This capacitance is for preventing POP ON/OFF noise.
- #5 These terminals are for JP-lines in case of using the same power supply (μPC1237H and Power Amplifier)
- #6 These terminals are for JP-lines in case of using the same power supply (μPC1270H and Power Tr)
- #7 This terminal is for AC-OFF Detection. Thus, use 8.2 k ohms instead of 22 k ohms, neglect 1SS53 terminals and neglect 4.7 μF in case of using DC power supply.
- #8 These capacitance are for preventing a parasitic oscillation. Use a 0.1 μF.
- #9 These trimmers are for adjusting an idling current. Recommend Neo-Pot P561 Series.
- #10 These capacitance are for the 3-terminals regulator input.
- #11 Design of 1 μH (example) 

#12 This indicates a copper board pattern

This is the evaluation circuit. Thus, it is not for a mass production considered about component deviation and the temperature characteristic.

