

- In accordance with IEC 61246
- E cores are supplied as single units

Magnetic characteristics (per set)

$$\Sigma l/A = 1,1 \text{ mm}^{-1}$$

$$l_e = 57,5 \text{ mm}$$

$$A_e = 52,5 \text{ mm}^2$$

$$A_{\min} = 51,5 \text{ mm}^2$$

$$V_e = 3\,020 \text{ mm}^3$$

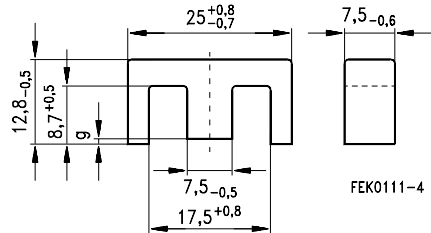

FEK0111-4

Approx. weight 16 g/set

Ungapped

Material	A_L value nH	μ_e	$A_{L1\min}$ nH	P_V W/set	Ordering code
N30	2900 + 30/- 20 %	2530			B66317-G-X130
N27	1750 + 30/- 20 %	1520	1440	0,59 (200 mT, 25 kHz, 100 °C)	B66317-G-X127
N67	1800 + 30/- 20 %	1570	1440	2,00 (200 mT, 100 kHz, 100 °C)	B66317-G-X167

Gapped

Material	g mm	A_L value approx. nH	μ_e	Ordering code ** = 27 (N27) = 67 (N67)
N27,	0,10 ± 0,02	489	425	B66317-G100-X1**
N67	0,16 ± 0,02	347	302	B66317-G160-X1**
	0,25 ± 0,02	250	218	B66317-G250-X1**
	0,50 ± 0,05	151	131	B66317-G500-X1**
	1,00 ± 0,05	91	79	B66317-G1000-X1**

The A_L value in the table applies to a core set comprising one ungapped core (dimension $g = 0$) and one gapped core (dimension $g > 0$).

Calculation factors (see page 423 for formulas)

Material	Relationship between air gap – A_L value		Calculation of saturation current			
	$K1$ (25 °C)	$K2$ (25 °C)	$K3$ (25 °C)	$K4$ (25 °C)	$K3$ (100 °C)	$K4$ (100 °C)
N27	90	- 0,731	139	- 0,847	129	- 0,865
N67	90	- 0,731	135	- 0,820	129	- 0,881

Validity range: $K1, K2$: 0,10 mm < s < 2,00 mm
 $K3, K4$: 60 nH < A_L < 570 nH

Coil former (magnetic axis horizontal or vertical)

Material: GFR polyterephthalate (UL 94 V-0, insulation class to IEC 60085:
 F \triangleq max. operating temperature 155 °C), color code black

Solderability: to IEC 60068-2-20, test Ta, method 1 (aging 3): 235 °C, 2 s

Resistance to soldering heat: to IEC 60068-2-20, test Tb, method 1B: 350 °C, 3,5 s

Winding: see page 159

Squared pins

Material: Stainless spring steel (0,25 mm)

Coil former						Ordering code
Figure	Sections	A_N mm ²	l_N mm	A_R value $\mu\Omega$	Pins	
1	1	61	50	28	10	B66208-A1110-T1
2	1	61	50	28	10	B66208-J1110-T1
Yoke (ordering code per piece, 2 are required)						B66208-A2010

Figure 1, horizontal version

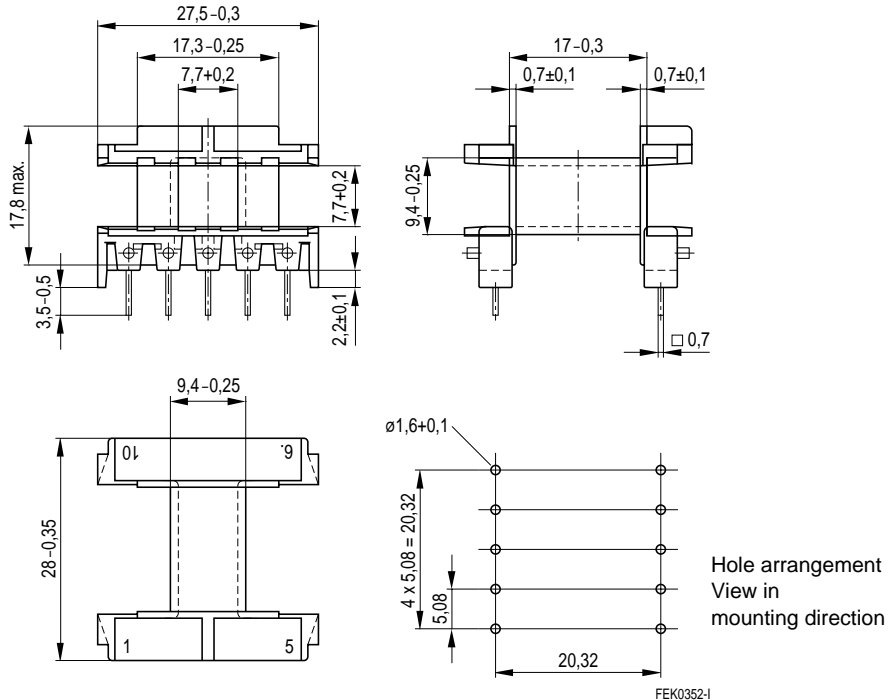
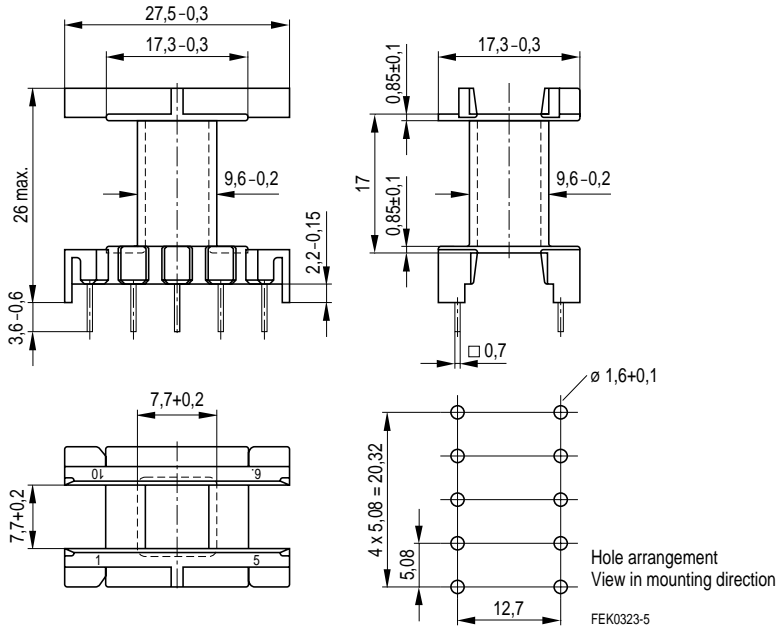
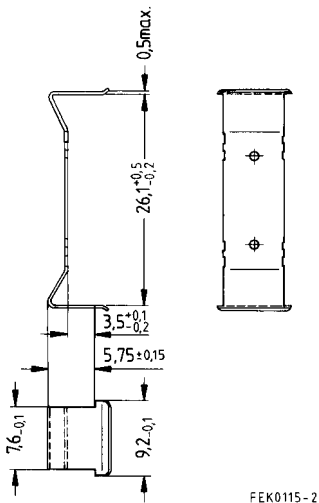

Figure 2, vertical version



Yoke



Coil former for SMPS transformers with line isolation

Material: GFR polyterephthalate (UL 94 V-0, insulation class to IEC 60085:
 F \triangleq max. operating temperature 155 °C), color code black

Solderability: to IEC 60068-2-20, test Ta, method 1 (aging 3): 235 °C, 2 s

Resistance to soldering heat: to IEC 60068-2-20, test Tb, method 1B: 350 °C, 3,5 s

Winding: see page 159

Squared pins

Yoke

Material: Nickel silver (0,3 mm) with ground terminal

Coil former					Ordering code
Sections	A_N mm ²	l_N mm	A_R value $\mu\Omega$	Pins	
1	56	52	32	9	B66208-J1009-T1
Yoke (ordering code per piece, 2 piece required)					B66208-A2003

Coil former

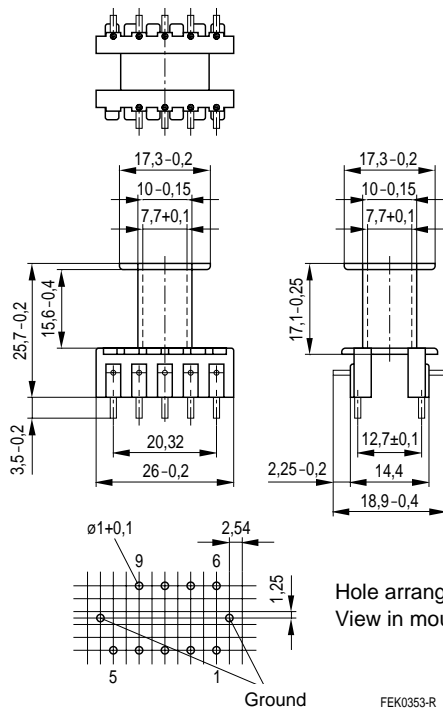

Yoke

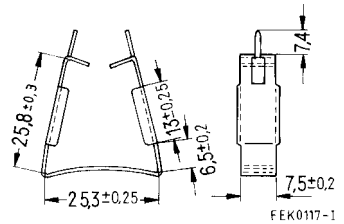

Hole arrangement
 View in mounting direction

FEK0353-R