

# MOS FIELD EFFECT POWER TRANSISTORS

## 2SK2134, 2SK2134-Z

### SWITCHING

### N-CHANNEL POWER MOS FET

### INDUSTRIAL USE

#### DESCRIPTION

The 2SK2134, 2SK2134-Z are N-channel Power MOS Field Effect Transistors designed for high voltage switching applications.

#### FEATURES

- Low On-state Resistance  
 $R_{DS(on)} = 0.4 \Omega \text{ MAX. (} V_{GS} = 10 \text{ V, } I_D = 7.0 \text{ A)}$
- Low  $C_{iss}$   $C_{iss} = 500 \text{ pF TYP.}$
- High Avalanche Capability Ratings

#### QUALITY GRADE

Standard

Please refer to "Quality grade on NEC Semiconductor Devices" (Document number IEI-1209) published by NEC Corporation to know the specification of quality grade on the devices and its recommended applications.

#### ABSOLUTE MAXIMUM RATINGS

Drain to Source Voltage	$V_{DSS}$	200	V
Gate to Source Voltage	$V_{GSS}$	$\pm 30$	V
Drain Current (DC)	$I_{D(DC)}$	$\pm 13$	A
Drain Current (pulse)	$I_{D(pulse)^*}$	$\pm 39$	A
Single Avalanche Current**	$I_{AS}$	13	A
Single Avalanche Energy**	$E_{AS}$	33.8	mJ
Total Power Dissipation ( $T_a = 25^\circ\text{C}$ )	$P_{T1}$	1.5	W
Total Power Dissipation ( $T_c = 25^\circ\text{C}$ )	$P_{T2}$	70	W
Storage Temperature	$T_{stg}$	-55 to +150	$^\circ\text{C}$
Channel Temperature	$T_{ch}$	150	$^\circ\text{C}$

\*  $PW \leq 10 \mu\text{s}$ , Duty Cycle  $\leq 1\%$

\*\* Starting  $T_{ch} = 25^\circ\text{C}$ ,  $R_{\theta} = 25 \Omega$ ,  $V_{GS} = 20 \text{ V} \rightarrow 0$

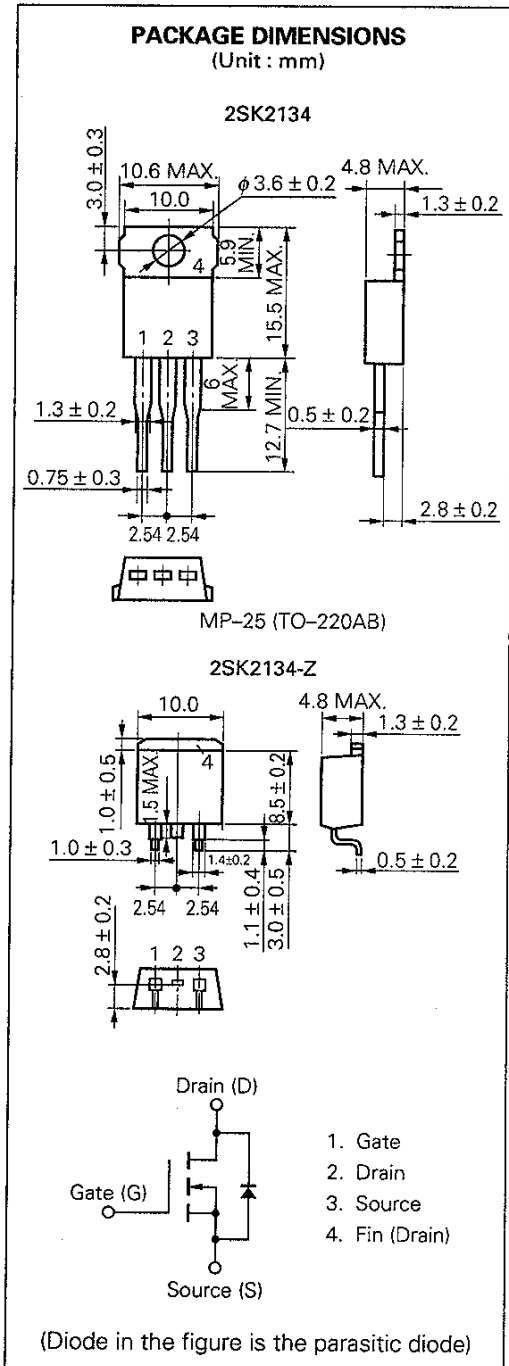

**ELECTRICAL CHARACTERISTICS (T<sub>a</sub> = 25 °C)**

CHARACTERISTIC	SYMBOL	MIN.	TYP.	MAX.	UNIT	TEST CONDITIONS
Drain to Source On-state Resistance	R <sub>DS(on)</sub>		0.3	0.4	Ω	V <sub>GS</sub> = 10 V, I <sub>D</sub> = 7.0 A
Gate to Source Cutoff Voltage	V <sub>GS(off)</sub>	2.0		4.0	V	V <sub>DS</sub> = 10 V, I <sub>D</sub> = 1 mA
Forward Transfer Admittance	y <sub>fs</sub>	2.0			S	V <sub>DS</sub> = 10 V, I <sub>D</sub> = 7.0 A
Drain Leakage Current	I <sub>DSS</sub>			100	μA	V <sub>DS</sub> = 200 V, V <sub>GS</sub> = 0
Gate to Source Leakage Current	I <sub>GSS</sub>			±100	nA	V <sub>GS</sub> = ±30 V, V <sub>DS</sub> = 0
Input Capacitance	C <sub>iss</sub>		500		pF	V <sub>DS</sub> = 10 V V <sub>GS</sub> = 0 f = 1 MHz
Output Capacitance	C <sub>oss</sub>		230		pF	
Reverse Transfer Capacitance	C <sub>rss</sub>		60		pF	
Turn-On Delay Time	t <sub>d(on)</sub>		12		ns	V <sub>GS</sub> = 10 V V <sub>DD</sub> = 100 V I <sub>D</sub> = 7.0 A, R <sub>G</sub> = 10 Ω R <sub>L</sub> = 14.3 Ω
Rise Time	t <sub>r</sub>		45		ns	
Turn-Off Delay Time	t <sub>d(off)</sub>		35		ns	
Fall Time	t <sub>f</sub>		12		ns	V <sub>GS</sub> = -10 V I <sub>D</sub> = 13 A V <sub>DD</sub> = 160 V
Total Gate Charge	Q <sub>G</sub>		15		nC	
Gate to Source Charge	Q <sub>GS</sub>		5.0		nC	
Gate to Drain Charge	Q <sub>GD</sub>		8.0		nC	
Diode Forward Voltage	V <sub>F(S-D)</sub>		1.0		V	I <sub>F</sub> = 13 A, V <sub>GS</sub> = 0
Reverse Recovery Time	t <sub>rr</sub>		200		ns	I <sub>F</sub> = 13 A
Reverse Recovery Charge	Q <sub>rr</sub>		0.6		μC	di/dt = 50 A/μs

**Test Circuit 1 : Avalanche Capability**

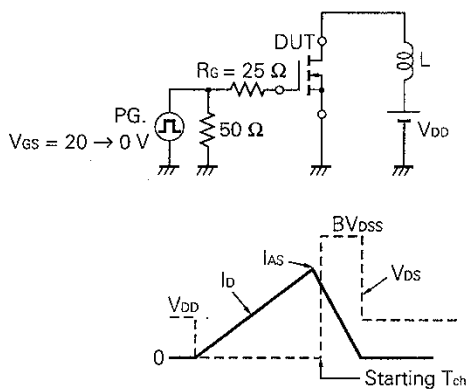

**Test Circuit 2 : Switching Time**

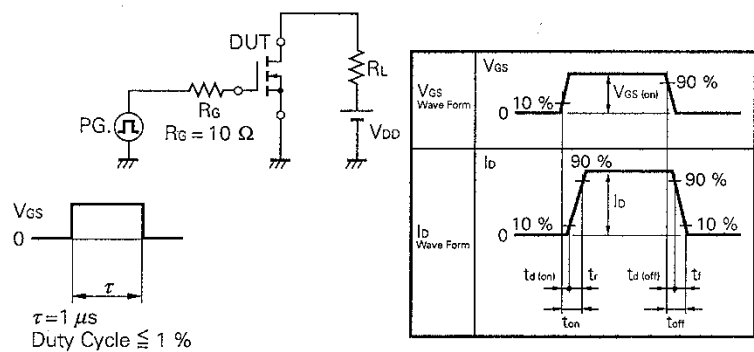

**Test Circuit 3 : Gate Charge**

