

STR-A6252

September 2005

■General Description

STR-A6252 is a PWM-topology off-line secondary-feedback switching regulator IC that builds in an power MOSEFT with avalanche immunity and a current-mode control chip. The auto-burst mode operation (intermittent burst operation) and a control chip with low power consumption improve the overall system efficiency. Since only a few external components are required, this IC simplifies the system design with high performance and low cost.

■Features

●DIP-8 package without pin 6 is ideal for low profile small power supply system

●PWM operational frequency jittering

The frequency jittering function suppresses EMI noise and consequently reduces the EMI noise filter cost

The center frequency of PWM operation is set to 50 KHz, and the frequency jittering provides variation of $\Delta f = 5\text{KHz}$ (typ), which is adjustable by the external capacitor.

●Over Load Protection (OLP) with a built-in timer (Auto restart)

Built-in delay timer circuit to trip the overload protection requires no external OLP capacitor, which allows cost reduction and space-saving.

●Over current protection (OCP) with constant current drooping

Constant output current drooping can be realized by simply adding two external resistors.

●Soft start

Reduces stress of the built-in power MOSFET

●Auto burst standby operation

Reduces standby input power less than 100mW at no load and 264VAC

Normal operation = PWM mode

Standby operation = Intermittent burst mode

●Less transformer's audible noise during the bust mode operation

●Built-in MOSFET guaranteeing avalanche energy capability

Simplifies the design of surge absorber, and requires no derating of the breakdown voltage.

●Start-up circuit

Thanks to the proprietary 900V BCD process, the built-in startup circuit connected to the internal MOSFET drain reduces both the discrete component count and the power consumption.

●Current Mode Feedback Control

●Leading Edge Blanking

●Various protections

Over current protection (OCP) Pulse By Pulse

Over load protection (OLP) Auto Restart

Over voltage protection (OVP) Latch

Thermal shut down (TSD)Latch

■Package---DIP8

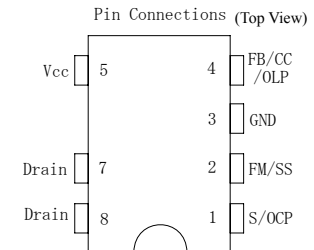

Pin No.	Symbols	Functions
1	Source/ O.C.P	MOSFET Source/ Over current protection
2	FM/SS	Capacitor connection terminal for frequency jitter modulation and soft start.
3	GND	Ground
4	FB /CC /OLP	Input of constant voltage control signal / constant current operation control signal / overload protection signal
5	Vcc	Input of power supply for control circuit
7	D	MOSFET drain / Input of Startup current
8		

■Applications

- Standby power supply
- Battery charger
- Small power S.M.P.S

■Key Specifications

Part Number	Fosc [kHz]	MOS FET VDSS[V]	RDS(ON) MAX	Pout[W] 230V / Universal
STR-A6252	50	650	2.8[Ω]	24W / 20W

Note 1.

The Pout [W] represents the thermal rating at PWM Operation, and the peak power of up to approx. 120 to 140% of the above value can be output. When the output voltage is low and ON-duty is narrow, the Pout [W] shall become lower than the above value.

STR-A6252

September 2005

Typical Application

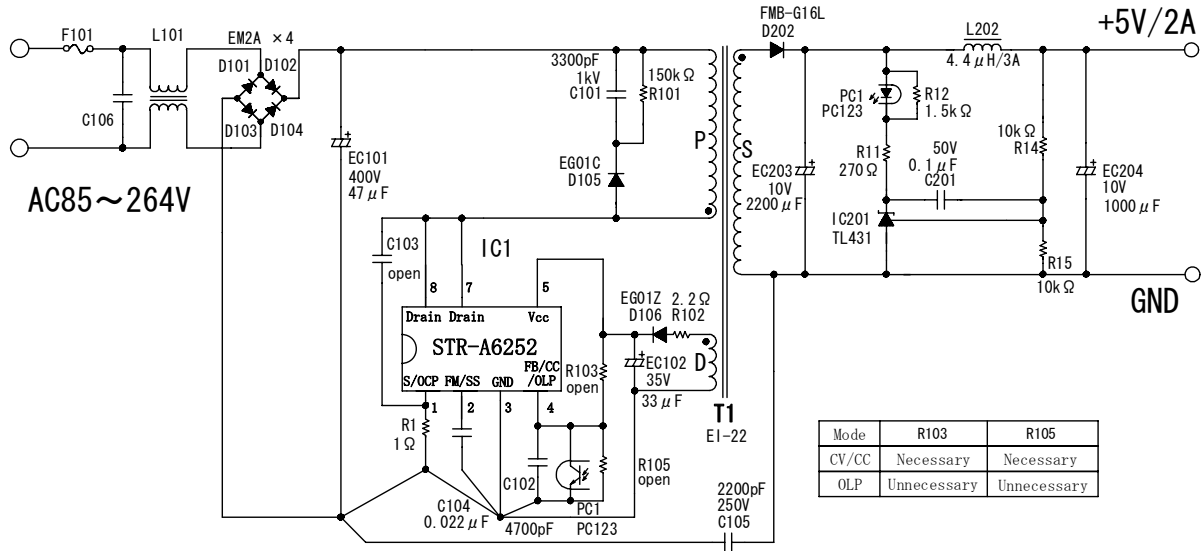

Block diagram

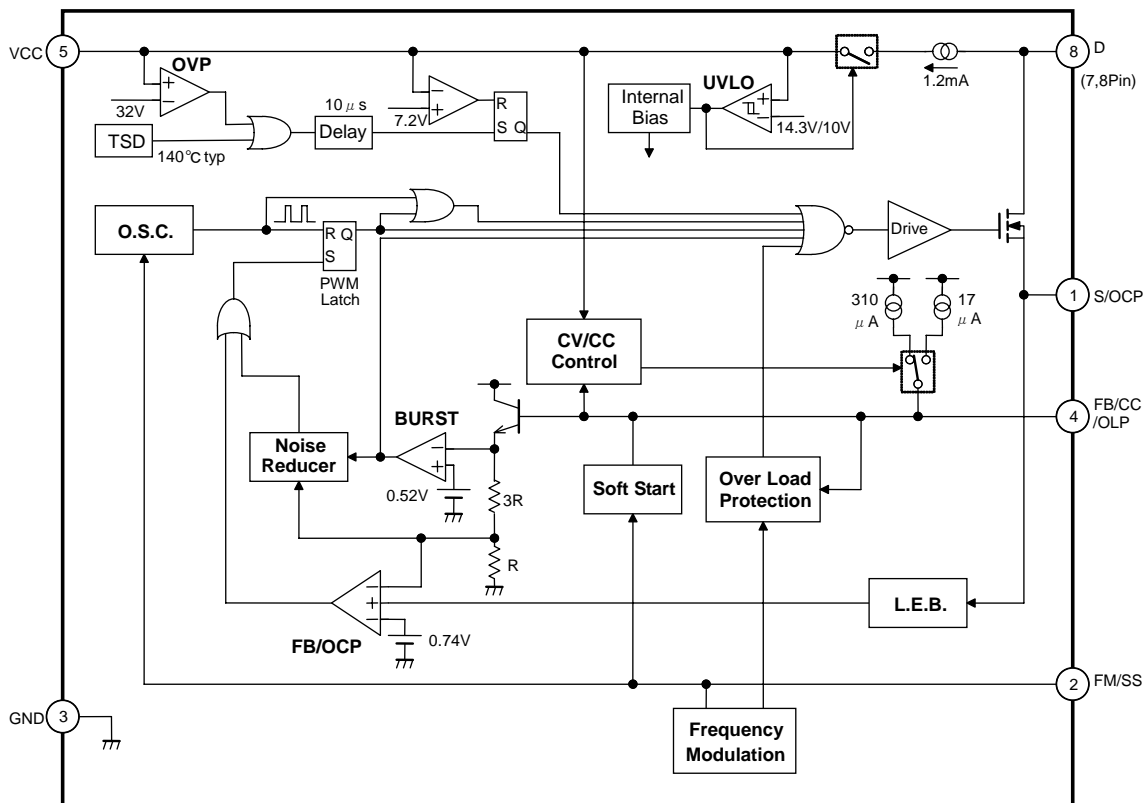

STR-A6252

September 2005

Absolute maximum ratings (Ta=25°C)

Parameter	Terminals	Symbol	Ratings	Units	Note
Drain Current	8-1	I_{Dpeak}^{*1}	3.0	A	Single Pulse
Maximum switching current	8-1	I_{Dmax}	3.0	A	$V_{1-3}=0.81V$ $T_a=-20\sim+125^{\circ}C$
Avalanche energy	8-1	E_{AS}^{*2}	123	mJ	Single Pulse
					$V_{DD}=99V, L=20mH$ $I_L=3.0A$
S/OCP pin voltage	1-3	$V_{O.C.P}$	-0.3 ~ 6	V	
Control supply voltage	5-3	V_{CC}	36	V	
FB/CC/OL pin voltage	4-3	$V_{F.B/O.L.P}$	-0.3 ~ 12	V	
FM pin voltage	2-3	V_{FM}	-0.3 ~ 6	V	
MOSFET power dissipation	8-1	P_{D1}^{*3}	1.35	W	*5
Control chip power dissipation	5-3	P_{D2}^{*4}	0.15	W	$P_{D2} = V_{CC} \times I_{CC}$
Internal frame temperature	-	T_F	-20 ~ +125	°C	
Operating temperature	-	T_{op}	-20 ~ +125	°C	
Storage temperature	-	T_{stg}	-40 ~ +125	°C	
Channel temperature	-	T_{ch}	+150	°C	

※1 Refer to MOS FET A.S.O curve

※2 Refer to MOS FET Tch-EAS curve

※3 Refer to MOS FET Ta-PD1 curve

※4 Refer to MIC TF-PD2 curve

※5 When embedding this hybrid IC onto the printed circuit board (board size 15mm×15mm)

STR-A6252

September 2005

Electrical characteristics

Electrical characteristics for control part (Ta=25°C)

Items	Terminals	Symbol	Ratings			Units
			Min	Typ	Max	
Operation start voltage	5 - 3	V _{cc(ON)}	12.9	14.3	15.7	V
Operation stop voltage	5 - 3	V _{cc(OFF)}	9	10	11	V
Operating current	5 - 3	I _{cc(ON)}	—	—	4	mA
Quiescent current at non-operation	5 - 3	I _{cc(OFF)}	—	—	25	μA
Average switching frequency	8 - 3	f _{osc(ave)}	45	50	55	KHz
Delta of frequency jittering	8 - 3	Δf	3	5	7	kHz
Maximum ON-Duty	8 - 3	D _{max}	70	76	82	%
FM pin high voltage	2 - 3	V _{HFM}	4.0	4.5	5.0	V
FM pin low voltage	2 - 3	V _{LFM}	3.2	3.6	4.0	V
FM pin source current	2 - 3	I _{src(FM)}	7.7	11	14.3	μA
FM pin sink current	2 - 3	I _{sink(FM)}	-14.3	-11	-7.7	μA
S/OCP threshold voltage	1 - 3	V _{OCP}	0.67	0.74	0.81	V
Leading edge blanking time	8 - 3	T _{bw}	220	320	420	Ns
Auto burst threshold voltage	4 - 3	V _{burst}	1.0	1.12	1.24	V
OLP threshold voltage	4 - 3	V _{OLP}	7.3	8.6	9.9	V
OLP source current	4 - 3	I _{OLP}	12	17	22	μA
OLP delay time	4 - 3	T _{OLP}	0.84	1.2	1.56	S
Maximum FB source current	4 - 3	I _{FB(MAX)}	220	310	400	μA
CC Set voltage	4 - 3	V _{SET(CC)}	4.9	5.8	6.7	V
CC Reset voltage	4 - 3	V _{RES(CC)}	3.5	3.9	4.3	V
Start up current	5 - 3	I _{startup}	0.77	1.1	1.43	mA
OVP activating voltage	5 - 3	V _{cc(OVP)}	28.8	32	35.2	V
Latch holding current *6	5 - 3	I _{cc(H)}	—	—	270	μA
Latch release voltage *6	5 - 3	V _{cc(La.OFF)}	5.9	7.2	8.6	V
Thermal shutdown temperature	—	T _{j(TSD)}	125	140	—	°C

*6 Latch is activated by only thermal or over voltage faults.

MOSFET electrical characteristics (Ta=25°C)

Items	Terminals	Symbol	Ratings			Units
			Min	Typ	Max	
Drain-to-Source breakdown voltage	8 - 1	V _{DSS}	650	—	—	V
Drain leakage current	8 - 1	I _{DSS}	—	—	300	μA
On-resistance	8 - 1	R _{DS(ON)}	—	—	2.8	Ω
Switching time	8 - 1	t _f	—	—	250	ns
Thermal resistance *7	-	θ _{ch-F}	—	—	52	°C/W

*7 Between channel and internal frame

Internal frame temperature (TF) is measured at the root of the Pin# 3.

STR-A6252

September 2005

STR-A6252

Fig1. A.S.O. temperature derating coefficient curve

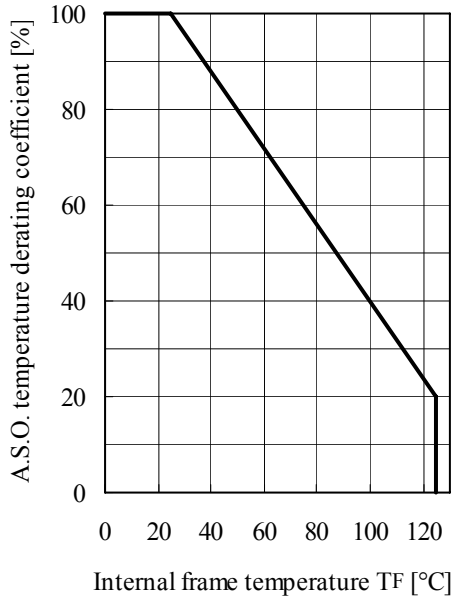

STR-A6252

Fig2. MOSFET A.S.O. Curve

Ta=25°C
Single Pulse

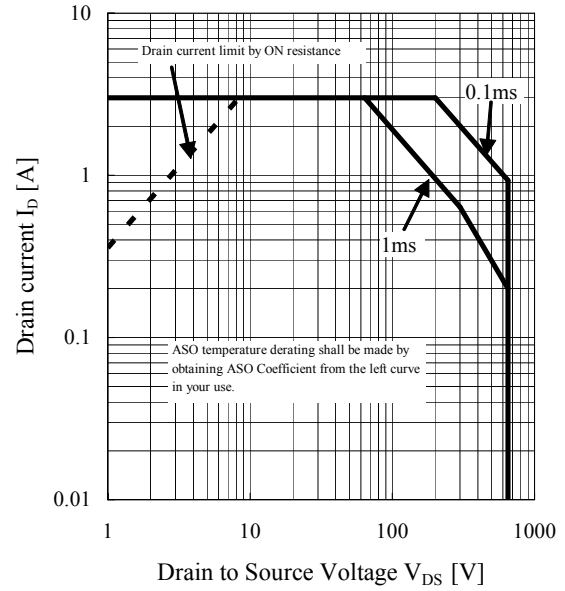

STR-A6252

Fig3. Avalanche energy derating curve

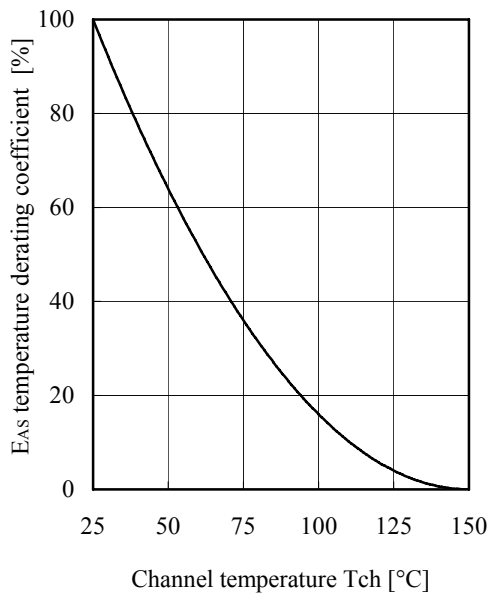

STR-A6252

September 2005

STR-A6252
Fig4. MOSFET Ta-P_{D1} curve

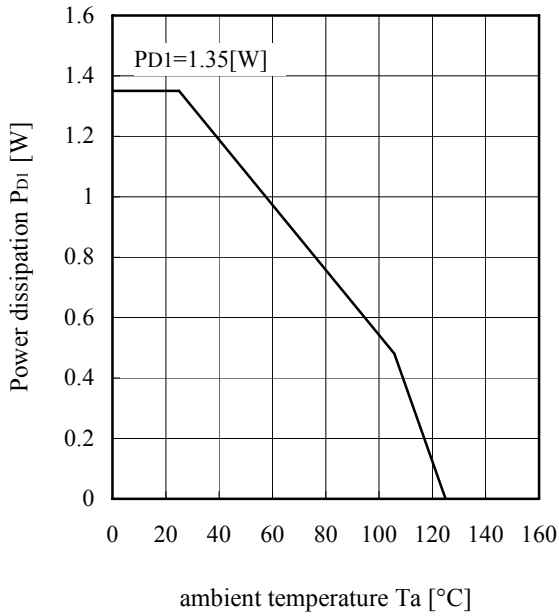

STR-A6252
Fig5. MIC T_F-P_{D2} curve

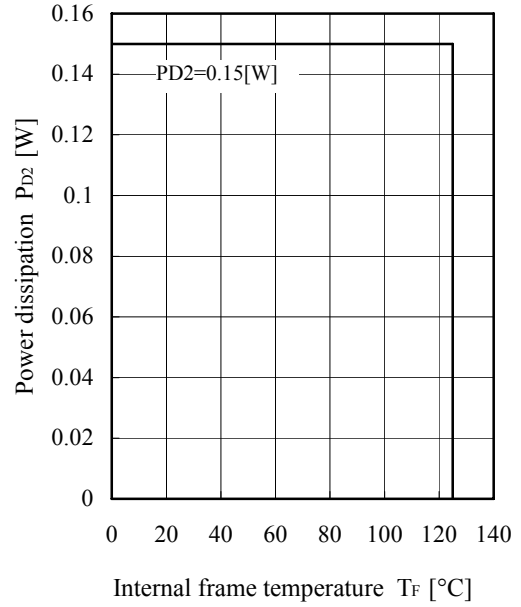

STR-A6252
Fig6. Transient thermal resistance curve

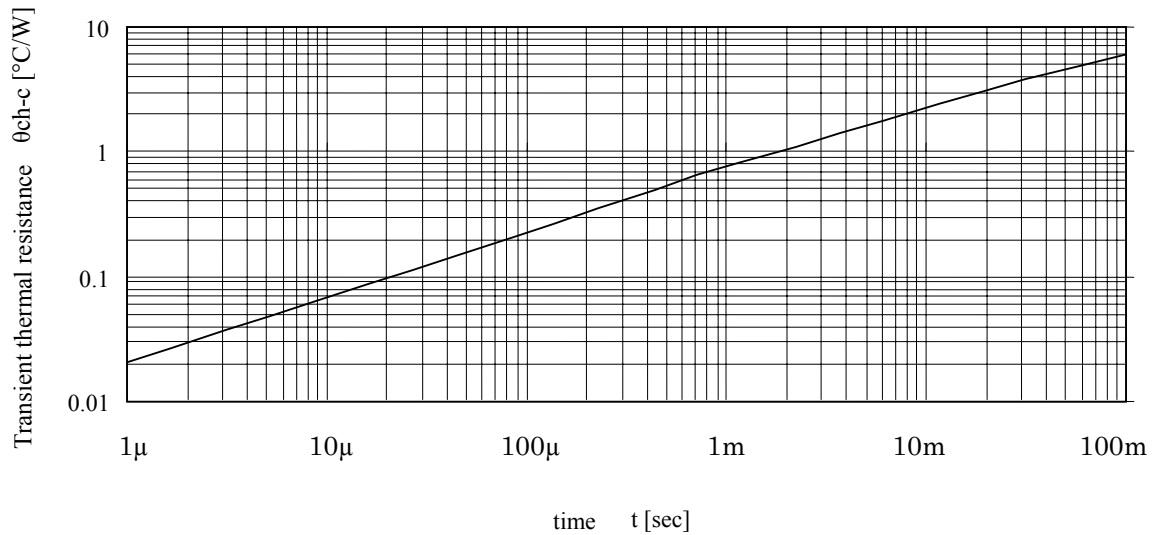

STR-A6252

September 2005

Outline

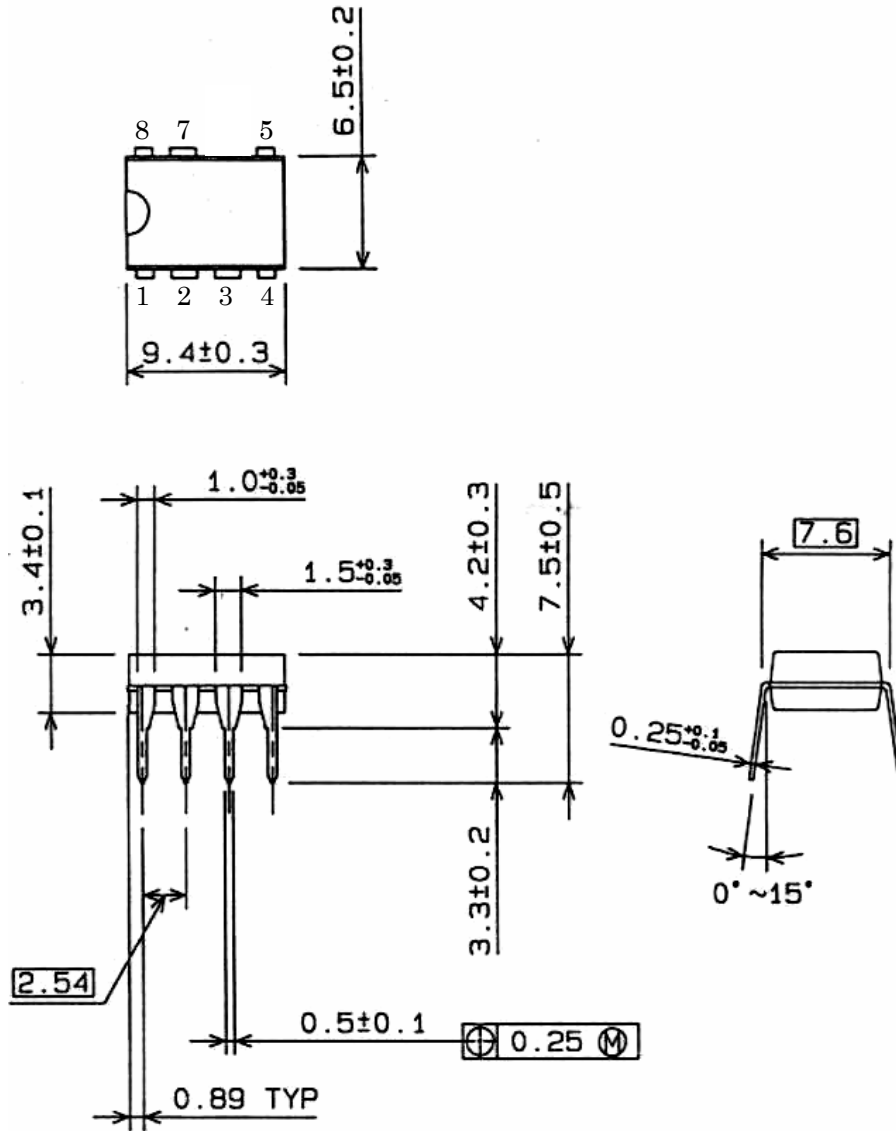

Unit : [mm]
Material of terminal : Cu
Treatment of terminal : solder plating (Pb Free)
Weight : Approx. 0.51[g]

STR-A6252

September 2005



Cautions and warnings

Since reliability can be affected adversely by improper storage environment and handling methods during Characteristic tests, please observe the following cautions.

Cautions for Storage

- Ensure that storage conditions comply with the standard temperature (5 to 35°C) and the standard relative humidity (around 40 to 75%) and avoid storage locations that experience extreme changes in temperature or humidity.
- Avoid locations where dust or harmful gases are present and avoid direct sunlight.
- Reinspect for rust in leads and solderability that have been stored for a long time.

Cautions for characteristic Tests and Handling

- When characteristic tests are carried out during inspection testing and other standard tests periods, protect the devices from surge of power from the testing device, shorts between the devices and the heat-sink.

Recommended operating temperature

- Inner frame temperature in operation TF=115[°C] MAX.

Soldering

- When soldering the products, please be sure to minimize the working time, within the following conditions.
 - 260±5°C 10sec.
 - 350±5°C 3sec. (Soldering iron)at a distance of 1.5mm from the main body of the Products

Considerations to protect the Products from Electrostatic Discharge

- When handling the devices, operator must be grounded. Grounded wrist straps be worn and should have at least 1MΩ of resistance near operators to ground to prevent shock hazard.
- Workbenches where the devices are handled should be grounded and be provided with conductive table and floor mats.
- When using measuring equipment such as a curve tracer, the equipment should also be grounded.
- When soldering the devices, the head of a soldering iron or a solder bath must be grounded in order to prevent leak voltage generated by them from being applied to the devices.
- The devices should always be stored and transported in our shipping containers or conductive containers, or be wrapped up in aluminum foil.

CAUTION / WARNING

- The information in this publication has been carefully checked and is believed to be accurate; however, no responsibility is assumed for inaccuracies.
 - Sanken reserves the right to make changes without further notice to any products herein in the interest of improvements in the performance, reliability, or manufacturability of its products.
Before placing an order, Sanken advises its customers to obtain the latest version of the relevant information to verify that the information being relied upon is current.
 - Application and operation examples described in this catalog are quoted for the sole purpose of reference for the use of the products herein and Sanken can assume no responsibility for any infringement of industrial property rights, intellectual property rights or any other rights of Sanken or any third party which may result from its use.
 - When using the products herein, the applicability and suitability of such products for the intended purpose or object shall be reviewed at the users' responsibility.
 - Although Sanken undertakes to enhance the quality and reliability of its products, the occurrence of failure and defect of semiconductor products at a certain rate is inevitable. Users of Sanken products are requested to take, at their own risk, preventative measures including safety design of the equipment or systems against any possible injury, death, fires or damages to the society due to device failure or malfunction.
 - Sanken products listed in this catalog are designed and intended for the use as components in general purpose electronic equipment or apparatus (home appliances, office equipment, telecommunication equipment, measuring equipment, etc.). Before placing an order, the user's written consent to the specifications is requested.
When considering the use of Sanken products in the applications where higher reliability is required (transportation equipment and its control systems, traffic signal control systems or equipment, fire/crime alarm systems, various safety devices, etc.), please contact your nearest Sanken sales representative to discuss and obtain written confirmation of your specifications. The use of Sanken products without the written consent of Sanken in the applications where extremely high reliability is required (aerospace equipment, nuclear power control systems, life support systems, etc.) is strictly prohibited.
 - Anti radioactive ray design is not considered for the products listed herein.
 - This publication shall not be reproduced in whole or in part without prior written approval from Sanken.
-
- This is notification that you, as purchaser of the products/technology, are not allowed to perform any of the following:
 1. Resell or retransfer these products/technology to any party intending to disturb international peace and security.
 2. Use these products/technology yourself for activities disturbing international peace and security.
 3. Allow any other party to use these products/technology for activities disturbing international peace and security.Also, as purchaser of these products/technology, you agree to follow the procedures for the export or transfer of these products/technology, under the Foreign Exchange and Foreign Trade Law, when you export or transfer the products/technology abroad.