

Silicon NPN Power Transistors

2SD600 2SD600K

DESCRIPTION

- With TO-126 package
- Complement to type 2SB631/631K
- High breakdown voltage V_{CE0} 100/120V
- High current 1A
- Low saturation voltage

APPLICATIONS

- For low-frequency power amplifier applications

PINNING

PIN	DESCRIPTION
1	Emitter
2	Collector;connected to mounting base
3	Base

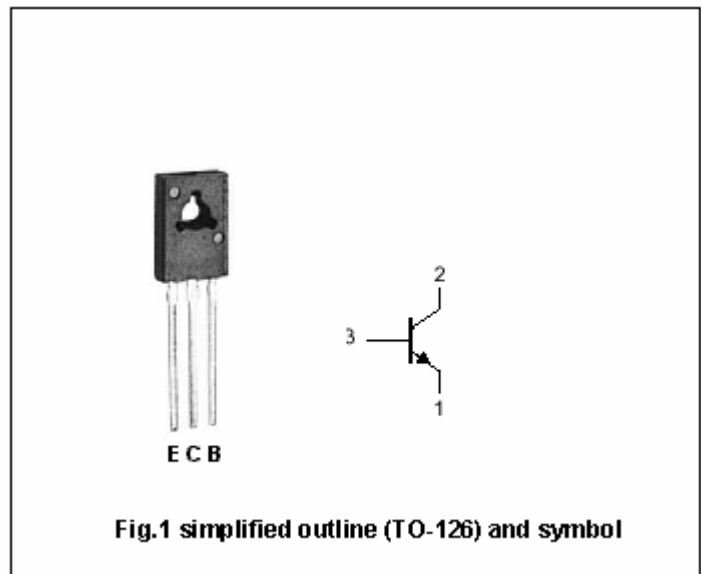
Absolute maximum ratings($T_a=25^\circ$)

SYMBOL	PARAMETER	CONDITIONS	VALUE	UNIT
V_{CBO}	Collector-base voltage	2SD600	100	V
		2SD600K		
V_{CEO}	Collector-emitter voltage	2SD600	100	V
		2SD600K		
V_{EBO}	Emitter-base voltage	Open collector	5	V
I_C	Collector current (DC)		1	A
I_{CM}	Collector current-peak		2	A
P_D	Total power dissipation	$T_a=25^\circ$	1	W
		$T_c=25^\circ$	8	
T_j	Junction temperature		150	$^\circ$
T_{stg}	Storage temperature		-55~150	$^\circ$

Silicon NPN Power Transistors

2SD600 2SD600K

CHARACTERISTICS

T_j=25 °C unless otherwise specified

SYMBOL	PARAMETER	CONDITIONS	MIN	TYP.	MAX	UNIT	
V _{(BR)CEO}	Collector-emitter breakdown voltage	2SD600	I _C =1mA; R _{BE} =∞	100			V
		2SD600K		120			
V _{(BR)CBO}	Collector-base breakdown voltage	2SD600	I _C =10μA; I _E =0	100			V
		2SD600K		120			
V _{(BR)EBO}	Emitter-base breakdown voltage	I _E =10μA; I _C =0	5			V	
V _{CEsat}	Collector-emitter saturation voltage	I _C =0.5A; I _B =50mA			0.4	V	
V _{BEsat}	Base-emitter saturation voltage	I _C =0.5A; I _B =50mA			1.2	V	
I _{CBO}	Collector cut-off current	V _{CB} =50V; I _E =0			1	μA	
I _{EBO}	Emitter cut-off current	V _{EB} =4V; I _C =0			1	μA	
h _{FE-1}	DC current gain	I _C =50mA; V _{CE} =5V	60		320		
h _{FE-2}	DC current gain	I _C =0.5A; V _{CE} =5V	20				
f _T	Transition frequency	I _C =50mA; V _{CE} =10V		130		MHz	
C _{OB}	Collector output capacitance	f=1MHz; V _{CB} =10V		20		pF	

Switching times

t _r	Fall time	I _C =500mA; V _{CE} =12V I _{B1} =-I _{B2} =50mA		0.1		μs
t _{off}	Turn-off time			0.5		μs
t _{stg}	Storage time			0.7		μs

◆ h_{FE-1} Classifications

D	E	F
60-120	100-200	160-320

Silicon NPN Power Transistors

2SD600 2SD600K

PACKAGE OUTLINE

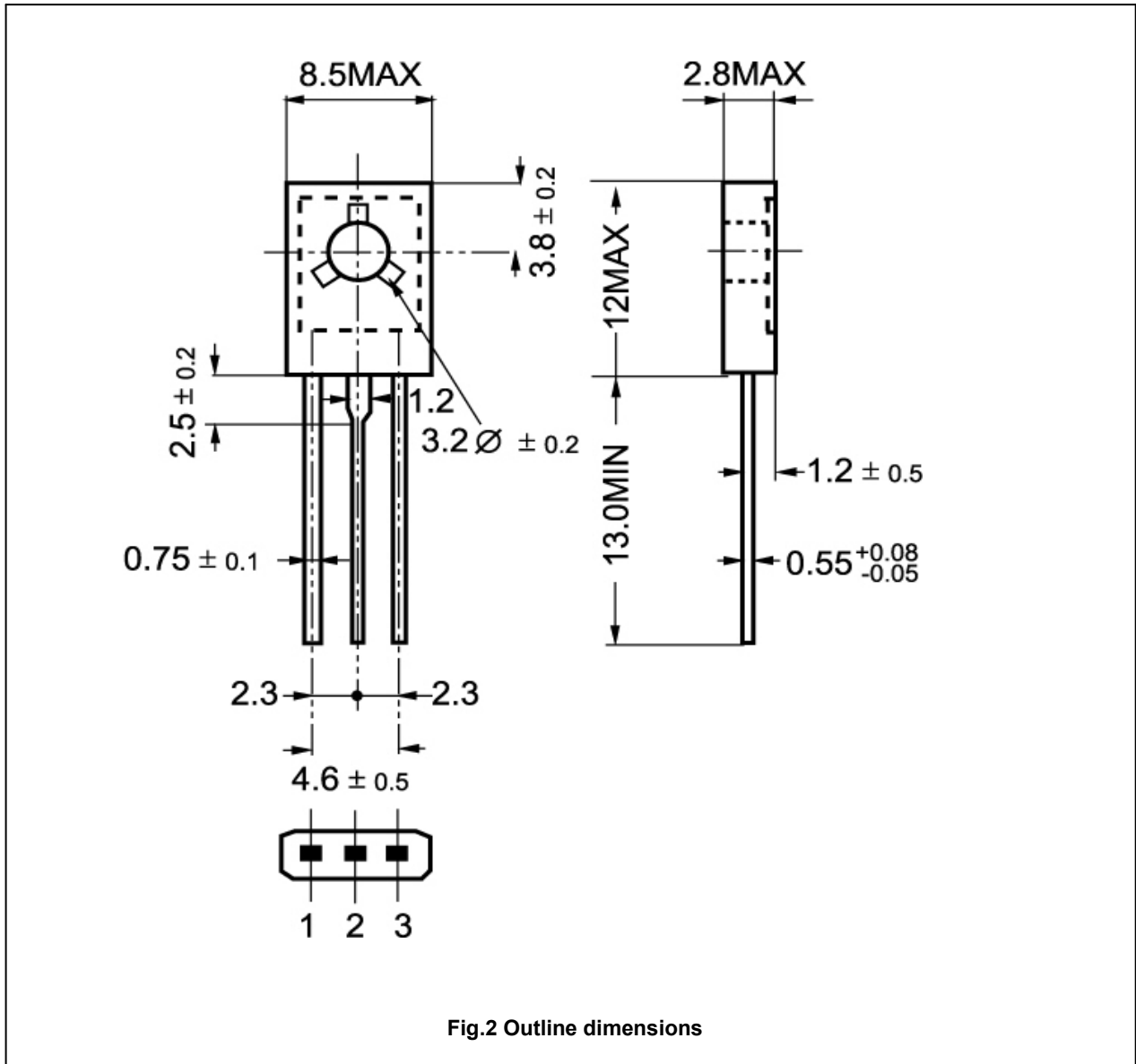

Fig.2 Outline dimensions

Silicon NPN Power Transistors

2SD600 2SD600K

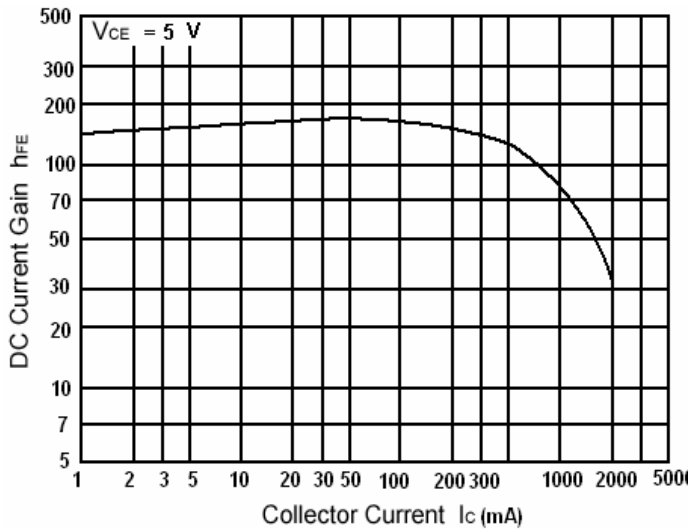

Fig.3 DC current Gain

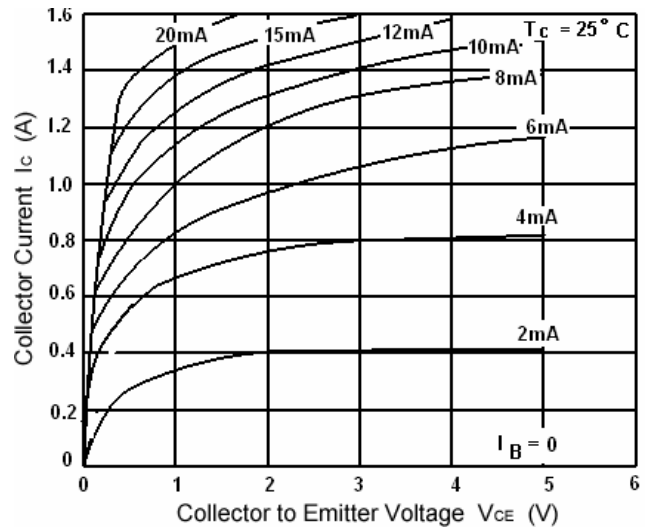

Fig.4 Static Characteristic

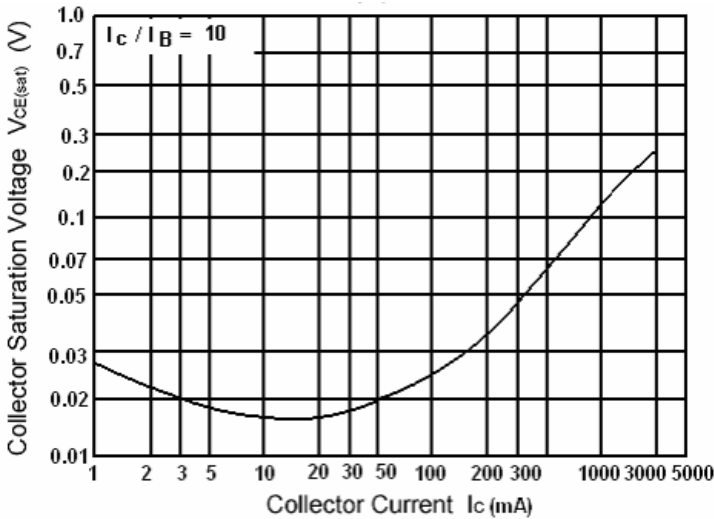

Fig.5 Collector-Emitter Saturation Voltage

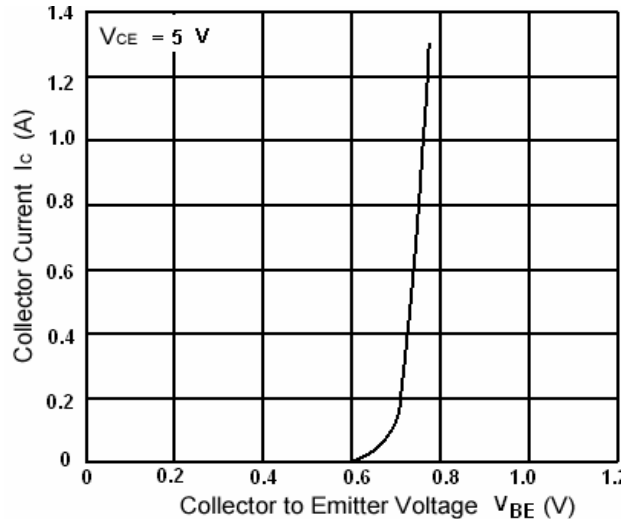

Fig.6 Base-Emitter On Voltage

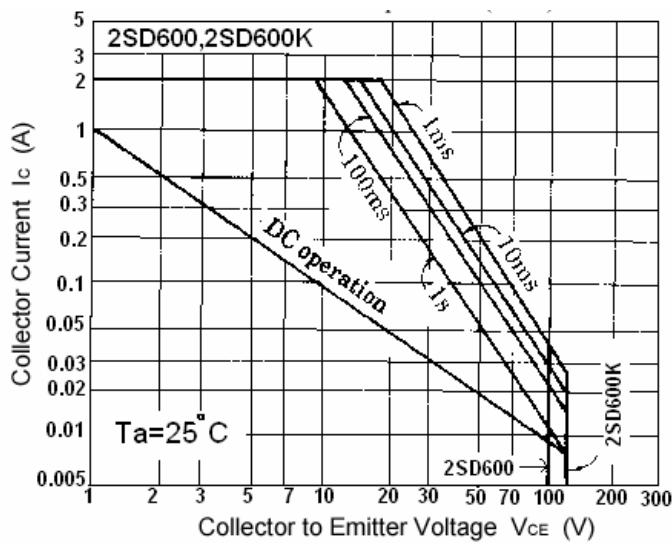

Fig.7 Safe Operating Area