

DATA SHEET

SJA1000 Stand-alone CAN controller

Product specification
Supersedes data of 1999 Aug 17
File under Integrated Circuits, IC18

2000 Jan 04

Stand-alone CAN controller**SJA1000**

CONTENTS			
1	FEATURES	6.5.3	Output Control Register (OCR)
2	GENERAL DESCRIPTION	6.5.4	Clock Divider Register (CDR)
3	ORDERING INFORMATION	7	LIMITING VALUES
4	BLOCK DIAGRAM	8	THERMAL CHARACTERISTICS
5	PINNING	9	DC CHARACTERISTICS
6	FUNCTIONAL DESCRIPTION	10	AC CHARACTERISTICS
6.1	Description of the CAN controller blocks	10.1	AC timing diagrams
6.1.1	Interface Management Logic (IML)	10.2	Additional AC information
6.1.2	Transmit Buffer (TXB)	11	PACKAGE OUTLINES
6.1.3	Receive Buffer (RXB, RXFIFO)	12	SOLDERING
6.1.4	Acceptance Filter (ACF)	12.1	Introduction
6.1.5	Bit Stream Processor (BSP)	12.2	DIP
6.1.6	Bit Timing Logic (BTL)	12.2.1	Soldering by dipping or by wave
6.1.7	Error Management Logic (EML)	12.2.2	Repairing soldered joints
6.2	Detailed description of the CAN controller	12.3	SO
6.2.1	PCA82C200 compatibility	12.3.1	Reflow soldering
6.2.2	Differences between BasicCAN and PeliCAN mode	12.3.2	Wave soldering
6.3	BasicCAN mode	12.3.3	Repairing soldered joints
6.3.1	BasicCAN address layout	13	DEFINITIONS
6.3.2	Reset values	14	LIFE SUPPORT APPLICATIONS
6.3.3	Control Register (CR)		
6.3.4	Command Register (CMR)		
6.3.5	Status Register (SR)		
6.3.6	Interrupt Register (IR)		
6.3.7	Transmit buffer layout		
6.3.8	Receive buffer		
6.3.9	Acceptance filter		
6.4	PeliCAN mode		
6.4.1	PeliCAN address layout		
6.4.2	Reset values		
6.4.3	Mode Register (MOD)		
6.4.4	Command Register (CMR)		
6.4.5	Status Register (SR)		
6.4.6	Interrupt Register (IR)		
6.4.7	Interrupt Enable Register (IER)		
6.4.8	Arbitration Lost Capture register (ALC)		
6.4.9	Error Code Capture register (ECC)		
6.4.10	Error Warning Limit Register (EWLR)		
6.4.11	RX Error Counter Register (RXERR)		
6.4.12	TX Error Counter Register (TXERR)		
6.4.13	Transmit buffer		
6.4.14	Receive buffer		
6.4.15	Acceptance filter		
6.4.16	RX Message Counter (RMC)		
6.4.17	RX Buffer Start Address register (RBSA)		
6.5	Common registers		
6.5.1	Bus Timing Register 0 (BTR0)		
6.5.2	Bus Timing Register 1 (BTR1)		

Stand-alone CAN controller

SJA1000

1 FEATURES

- Pin compatibility to the PCA82C200 stand-alone CAN controller
- Electrical compatibility to the PCA82C200 stand-alone CAN controller
- PCA82C200 mode (BasicCAN mode is default)
- Extended receive buffer (64-byte FIFO)
- CAN 2.0B protocol compatibility (extended frame passive in PCA82C200 compatibility mode)
- Supports 11-bit identifier as well as 29-bit identifier
- Bit rates up to 1 Mbits/s
- PeliCAN mode extensions:
 - Error counters with read/write access
 - Programmable error warning limit
 - Last error code register
 - Error interrupt for each CAN-bus error
 - Arbitration lost interrupt with detailed bit position
 - Single-shot transmission (no re-transmission)
 - Listen only mode (no acknowledge, no active error flags)
 - Hot plugging support (software driven bit rate detection)
 - Acceptance filter extension (4-byte code, 4-byte mask)
 - Reception of 'own' messages (self reception request)
- 24 MHz clock frequency
- Interfaces to a variety of microprocessors
- Programmable CAN output driver configuration
- Extended ambient temperature range (–40 to +125 °C).

2 GENERAL DESCRIPTION

The SJA1000 is a stand-alone controller for the Controller Area Network (CAN) used within automotive and general industrial environments. It is the successor of the PCA82C200 CAN controller (BasicCAN) from Philips Semiconductors. Additionally, a new mode of operation is implemented (PeliCAN) which supports the CAN 2.0B protocol specification with several new features.

3 ORDERING INFORMATION

TYPE NUMBER	PACKAGE		
	NAME	DESCRIPTION	VERSION
SJA1000	DIP28	plastic dual in-line package; 28 leads (600 mil)	SOT117-1
SJA1000T	SO28	plastic small outline package; 28 leads; body width 7.5 mm	SOT136-1

Stand-alone CAN controller

SJA1000

4 BLOCK DIAGRAM

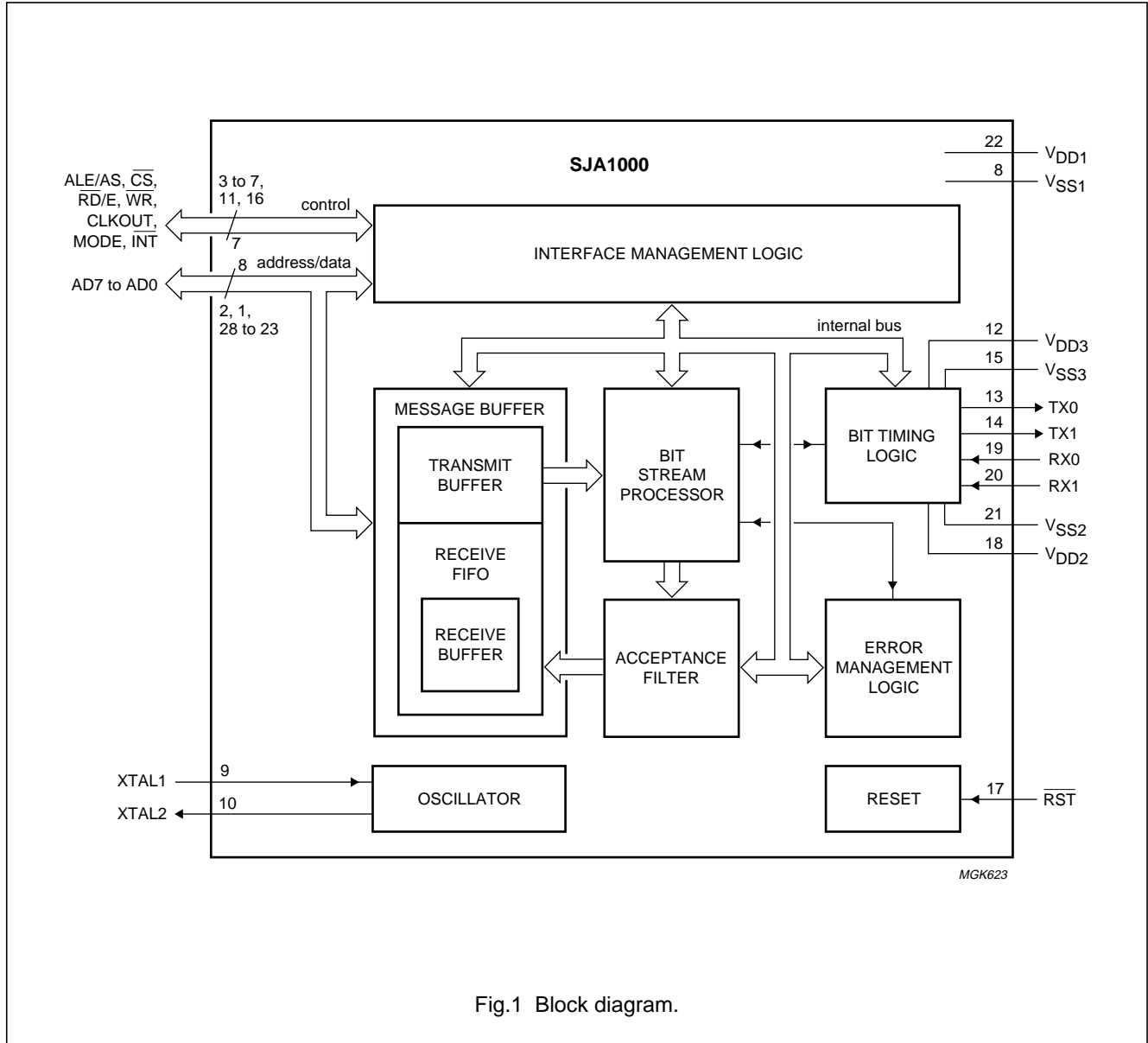

Fig.1 Block diagram.

Stand-alone CAN controller

SJA1000

5 PINNING

SYMBOL	PIN	DESCRIPTION
AD7 to AD0	2, 1, 28 to 23	multiplexed address/data bus
ALE/AS	3	ALE input signal (Intel mode), AS input signal (Motorola mode)
$\overline{\text{CS}}$	4	chip select input, LOW level allows access to the SJA1000
$\overline{\text{RD/E}}$	5	$\overline{\text{RD}}$ signal (Intel mode) or E enable signal (Motorola mode) from the microcontroller
$\overline{\text{WR}}$	6	$\overline{\text{WR}}$ signal (Intel mode) or $\overline{\text{RD/WR}}$ signal (Motorola mode) from the microcontroller
CLKOUT	7	clock output signal produced by the SJA1000 for the microcontroller; the clock signal is derived from the built-in oscillator via the programmable divider; the clock off bit within the clock divider register allows this pin to disable
V_{SS1}	8	ground for logic circuits
XTAL1	9	input to the oscillator amplifier; external oscillator signal is input via this pin; note 1
XTAL2	10	output from the oscillator amplifier; the output must be left open-circuit when an external oscillator signal is used; note 1
MODE	11	mode select input 1 = selects Intel mode 0 = selects Motorola mode
V_{DD3}	12	5 V supply for output driver
TX0	13	output from the CAN output driver 0 to the physical bus line
TX1	14	output from the CAN output driver 1 to the physical bus line
V_{SS3}	15	ground for output driver
$\overline{\text{INT}}$	16	interrupt output, used to interrupt the microcontroller; $\overline{\text{INT}}$ is active LOW if any bit of the internal interrupt register is set; $\overline{\text{INT}}$ is an open-drain output and is designed to be a wired-OR with other $\overline{\text{INT}}$ outputs within the system; a LOW level on this pin will reactivate the IC from sleep mode
$\overline{\text{RST}}$	17	reset input, used to reset the CAN interface (active LOW); automatic power-on reset can be obtained by connecting $\overline{\text{RST}}$ via a capacitor to V_{SS} and a resistor to V_{DD} (e.g. $C = 1 \mu\text{F}$; $R = 50 \text{ k}\Omega$)
V_{DD2}	18	5 V supply for input comparator
RX0, RX1	19, 20	input from the physical CAN-bus line to the input comparator of the SJA1000; a dominant level will wake up the SJA1000 if sleeping; a dominant level is read, if RX1 is higher than RX0 and vice versa for the recessive level; if the CBP bit (see Table 49) is set in the clock divider register, the CAN input comparator is bypassed to achieve lower internal delays if an external transceiver circuitry is connected to the SJA1000; in this case only RX0 is active; HIGH is interpreted as recessive level and LOW is interpreted as dominant level
V_{SS2}	21	ground for input comparator
V_{DD1}	22	5 V supply for logic circuits

Note

1. XTAL1 and XTAL2 pins should be connected to V_{SS1} via 15 pF capacitors.

Stand-alone CAN controller

SJA1000

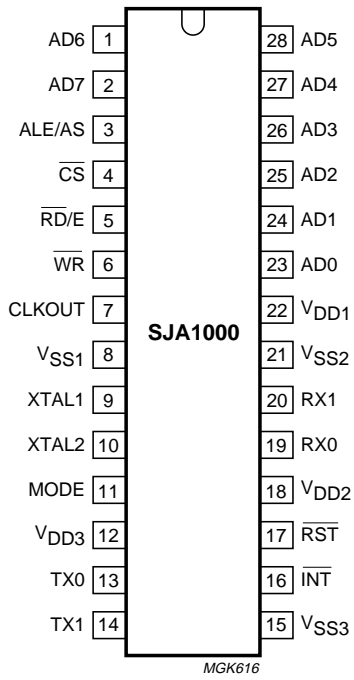

Fig.2 Pin configuration (DIP28).

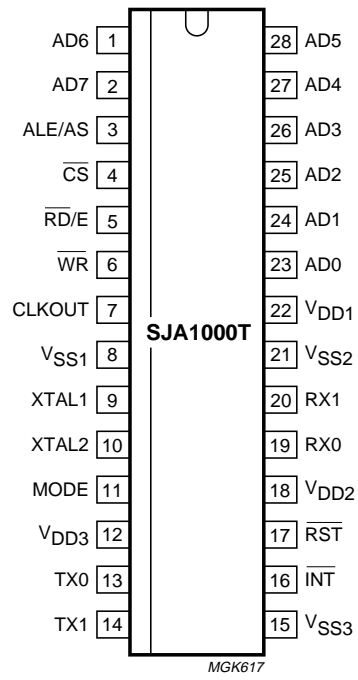

Fig.3 Pin configuration (SO28).

Stand-alone CAN controller

SJA1000

6 FUNCTIONAL DESCRIPTION

6.1 Description of the CAN controller blocks

6.1.1 INTERFACE MANAGEMENT LOGIC (IML)

The interface management logic interprets commands from the CPU, controls addressing of the CAN registers and provides interrupts and status information to the host microcontroller.

6.1.2 TRANSMIT BUFFER (TXB)

The transmit buffer is an interface between the CPU and the Bit Stream Processor (BSP) that is able to store a complete message for transmission over the CAN network. The buffer is 13 bytes long, written to by the CPU and read out by the BSP.

6.1.3 RECEIVE BUFFER (RXB, RXFIFO)

The receive buffer is an interface between the acceptance filter and the CPU that stores the received and accepted messages from the CAN-bus line. The Receive Buffer (RXB) represents a CPU-accessible 13-byte window of the Receive FIFO (RXFIFO), which has a total length of 64 bytes.

With the help of this FIFO the CPU is able to process one message while other messages are being received.

6.1.4 ACCEPTANCE FILTER (ACF)

The acceptance filter compares the received identifier with the acceptance filter register contents and decides whether this message should be accepted or not. In the event of a positive acceptance test, the complete message is stored in the RXFIFO.

6.1.5 BIT STREAM PROCESSOR (BSP)

The bit stream processor is a sequencer which controls the data stream between the transmit buffer, RXFIFO and the CAN-bus. It also performs the error detection, arbitration, stuffing and error handling on the CAN-bus.

6.1.6 BIT TIMING LOGIC (BTL)

The bit timing logic monitors the serial CAN-bus line and handles the bus line-related bit timing. It is synchronized to the bit stream on the CAN-bus on a 'recessive-to-dominant' bus line transition at the beginning of a message (hard synchronization) and re-synchronized on further transitions during the reception of a message (soft synchronization). The BTL also provides programmable time segments to compensate for the propagation delay times and phase shifts (e.g. due to

oscillator drifts) and to define the sample point and the number of samples to be taken within a bit time.

6.1.7 ERROR MANAGEMENT LOGIC (EML)

The EML is responsible for the error confinement of the transfer-layer modules. It receives error announcements from the BSP and then informs the BSP and IML about error statistics.

6.2 Detailed description of the CAN controller

The SJA1000 is designed to be software and pin-compatible to its predecessor, the PCA82C200 stand-alone CAN controller. Additionally, a lot of new functions are implemented. To achieve the software compatibility, two different modes of operation are implemented:

- BasicCAN mode; PCA82C200 compatible
- PeliCAN mode; extended features.

The mode of operation is selected with the CAN-mode bit located within the clock divider register. Default mode upon reset is the BasicCAN mode.

6.2.1 PCA82C200 COMPATIBILITY

In BasicCAN mode the SJA1000 emulates all known registers from the PCA82C200 stand-alone CAN controller. The characteristics, as described in Sections 6.2.1.1 to 6.2.1.4 are different from the PCA82C200 design with respect to software compatibility.

6.2.1.1 Synchronization mode

The SYNC bit in the control register is removed (CR.6 in the PCA82C200). Synchronization is only possible by a recessive-to-dominant transition on the CAN-bus. Writing to this bit has no effect. To achieve compatibility to existing application software, a read access to this bit will reflect the previously written value (flip-flop without effect).

6.2.1.2 Clock divider register

The clock divider register is used to select the CAN mode of operation (BasicCAN/PeliCAN). Therefore one of the reserved bits within the PCA82C200 is used. Writing a value between 0 and 7, as allowed for the PCA82C200, will enter the BasicCAN mode. The default state is divide by 12 for Motorola mode and divide by 2 for Intel mode. An additional function is implemented within another of the reserved bits. Setting of bit CBP (see Table 49) enables the internal RX input comparator to be bypassed thereby reducing the internal delays if an external transceiver circuit is used.

Stand-alone CAN controller

SJA1000

6.2.1.3 Receive buffer

The dual receive buffer concept of the PCA82C200 is replaced by the receive FIFO from the PeliCAN controller. This has no effect to the application software except for the data overrun probability. Now more than two messages may be received (up to 64 bytes) until a data overrun occurs.

6.2.1.4 CAN 2.0B

The SJA1000 is designed to support the full CAN 2.0B protocol specification, which means that the extended oscillator tolerance is implemented as well as the processing of extended frame messages. In BasicCAN mode it is possible to transmit and receive standard frame messages only (11-bit identifier). If extended frame messages (29-bit identifier) are detected on the CAN-bus, they are tolerated and an acknowledge is given if the message was correct, but there is no receive interrupt generated.

6.2.2 DIFFERENCES BETWEEN BASICCAN AND PELICAN MODE

In the PeliCAN mode the SJA1000 appears with a re-organized register mapping with a lot of new features. All known bits from the PCA82C200 design are available as well as several new ones. In the PeliCAN mode the complete CAN 2.0B functionality is supported (29-bit identifier).

Main new features of the SJA1000 are:

- Reception and transmission of standard and extended frame format messages
- Receive FIFO (64-byte)
- Single/dual acceptance filter with mask and code register for standard and extended frame
- Error counters with read/write access
- Programmable error warning limit
- Last error code register
- Error interrupt for each CAN-bus error
- Arbitration lost interrupt with detailed bit position
- Single-shot transmission (no re-transmission on error or arbitration lost)
- Listen only mode (monitoring of the CAN-bus, no acknowledge, no error flags)
- Hot plugging supported (disturbance-free software driven bit rate detection)
- Disable CLKOUT by hardware.

6.3 BasicCAN mode

6.3.1 BASICCAN ADDRESS LAYOUT

The SJA1000 appears to a microcontroller as a memory-mapped I/O device. An independent operation of both devices is guaranteed by a RAM-like implementation of the on-chip registers.

The address area of the SJA1000 consists of the control segment and the message buffers. The control segment is programmed during an initialization download in order to configure communication parameters (e.g. bit timing). Communication over the CAN-bus is also controlled via this segment by the microcontroller. During initialization the CLKOUT signal may be programmed to a value determined by the microcontroller.

A message, which should be transmitted, has to be written to the transmit buffer. After a successful reception the microcontroller may read the received message from the receive buffer and then release it for further use.

The exchange of status, control and command signals between the microcontroller and the SJA1000 is performed in the control segment. The layout of this segment is shown in Table 3. After an initial download, the contents of the registers acceptance code, acceptance mask, bus timing registers 0 and 1 and output control should not be changed. Therefore these registers may only be accessed when the reset request bit in the control register is set HIGH.

For register access, two different modes have to be distinguished:

- Reset mode
- Operating mode.

The reset mode (see Table 3, control register, bit Reset Request) is entered automatically after a hardware reset or when the controller enters the bus-off state (see Table 5, status register, bit Bus Status). The operating mode is activated by resetting of the reset request bit in the control register.

Stand-alone CAN controller

SJA1000

Table 1 BasicCAN address allocation; note 1

CAN ADDRESS	SEGMENT	OPERATING MODE		RESET MODE	
		READ	WRITE	READ	WRITE
0	control	control	control	control	control
1		(FFH)	command	(FFH)	command
2		status	–	status	–
3		interrupt	–	interrupt	–
4		(FFH)	–	acceptance code	acceptance code
5		(FFH)	–	acceptance mask	acceptance mask
6		(FFH)	–	bus timing 0	bus timing 0
7		(FFH)	–	bus timing 1	bus timing 1
8		(FFH)	–	output control	output control
9		test	test; note 2	test	test; note 2
10	transmit buffer	identifier (10 to 3)	identifier (10 to 3)	(FFH)	–
11		identifier (2 to 0), RTR and DLC	identifier (2 to 0), RTR and DLC	(FFH)	–
12		data byte 1	data byte 1	(FFH)	–
13		data byte 2	data byte 2	(FFH)	–
14		data byte 3	data byte 3	(FFH)	–
15		data byte 4	data byte 4	(FFH)	–
16		data byte 5	data byte 5	(FFH)	–
17		data byte 6	data byte 6	(FFH)	–
18		data byte 7	data byte 7	(FFH)	–
19		data byte 8	data byte 8	(FFH)	–
20	receive buffer	identifier (10 to 3)	identifier (10 to 3)	identifier (10 to 3)	identifier (10 to 3)
21		identifier (2 to 0), RTR and DLC	identifier (2 to 0), RTR and DLC	identifier (2 to 0), RTR and DLC	identifier (2 to 0), RTR and DLC
22		data byte 1	data byte 1	data byte 1	data byte 1
23		data byte 2	data byte 2	data byte 2	data byte 2
24		data byte 3	data byte 3	data byte 3	data byte 3
25		data byte 4	data byte 4	data byte 4	data byte 4
26		data byte 5	data byte 5	data byte 5	data byte 5
27		data byte 6	data byte 6	data byte 6	data byte 6
28		data byte 7	data byte 7	data byte 7	data byte 7
29		data byte 8	data byte 8	data byte 8	data byte 8
30		(FFH)	–	(FFH)	–
31		clock divider	clock divider; note 3	clock divider	clock divider

Notes

1. It should be noted that the registers are repeated within higher CAN address areas (the most significant bits of the 8-bit CPU address are not decoded: CAN address 32 continues with CAN address 0 and so on).
2. Test register is used for production testing only. Using this register during normal operation may result in undesired behaviour of the device.
3. Some bits are writeable in reset mode only (CAN mode and CBP).

Stand-alone CAN controller

SJA1000

6.3.2 RESET VALUES

Detection of a 'reset request' results in aborting the current transmission/reception of a message and entering the reset mode. On the '1-to-0' transition of the reset request bit, the CAN controller returns to the operating mode.

Table 2 Reset mode configuration; notes 1 and 2

REGISTER	BIT	SYMBOL	NAME	VALUE	
				RESET BY HARDWARE	SETTING BIT CR.0 BY SOFTWARE OR DUE TO BUS-OFF
Control	CR.7	–	reserved	0	0
	CR.6	–	reserved	X	X
	CR.5	–	reserved	1	1
	CR.4	OIE	Overrun Interrupt Enable	X	X
	CR.3	EIE	Error Interrupt Enable	X	X
	CR.2	TIE	Transmit Interrupt Enable	X	X
	CR.1	RIE	Receive Interrupt Enable	X	X
	CR.0	RR	Reset Request	1 (reset mode)	1 (reset mode)
Command	CMR.7	–	reserved	note 3	note 3
	CMR.6	–	reserved		
	CMR.5	–	reserved		
	CMR.4	GTS	Go To Sleep		
	CMR.3	CDO	Clear Data Overrun		
	CMR.2	RRB	Release Receive Buffer		
	CMR.1	AT	Abort Transmission		
	CMR.0	TR	Transmission Request		
Status	SR.7	BS	Bus Status	0 (bus-on)	X
	SR.6	ES	Error Status	0 (ok)	X
	SR.5	TS	Transmit Status	0 (idle)	0 (idle)
	SR.4	RS	Receive Status	0 (idle)	0 (idle)
	SR.3	TCS	Transmission Complete Status	1 (complete)	X
	SR.2	TBS	Transmit Buffer Status	1 (released)	1 (released)
	SR.1	DOS	Data Overrun Status	0 (absent)	0 (absent)
	SR.0	RBS	Receive Buffer Status	0 (empty)	0 (empty)
Interrupt	IR.7	–	reserved	1	1
	IR.6	–	reserved	1	1
	IR.5	–	reserved	1	1
	IR.4	WUI	Wake-Up Interrupt	0 (reset)	0 (reset)
	IR.3	DOI	Data Overrun Interrupt	0 (reset)	0 (reset)
	IR.2	EI	Error Interrupt	0 (reset)	X; note 4
	IR.1	TI	Transmit Interrupt	0 (reset)	0 (reset)
	IR.0	RI	Receive Interrupt	0 (reset)	0 (reset)

Stand-alone CAN controller

SJA1000

REGISTER	BIT	SYMBOL	NAME	VALUE	
				RESET BY HARDWARE	SETTING BIT CR.0 BY SOFTWARE OR DUE TO BUS-OFF
Acceptance code	AC.7 to 0	AC	Acceptance Code	X	X
Acceptance mask	AM.7 to 0	AM	Acceptance Mask	X	X
Bus timing 0	BTR0.7	SJW.1	Synchronization Jump Width 1	X	X
	BTR0.6	SJW.0	Synchronization Jump Width 0	X	X
	BTR0.5	BRP.5	Baud Rate Prescaler 5	X	X
	BTR0.4	BRP.4	Baud Rate Prescaler 4	X	X
	BTR0.3	BRP.3	Baud Rate Prescaler 3	X	X
	BTR0.2	BRP.2	Baud Rate Prescaler 2	X	X
	BTR0.1	BRP.1	Baud Rate Prescaler 1	X	X
	BTR0.0	BRP.0	Baud Rate Prescaler 0	X	X
Bus timing 1	BTR1.7	SAM	Sampling	X	X
	BTR1.6	TSEG2.2	Time Segment 2.2	X	X
	BTR1.5	TSEG2.1	Time Segment 2.1	X	X
	BTR1.4	TSEG2.0	Time Segment 2.0	X	X
	BTR1.3	TSEG1.3	Time Segment 1.3	X	X
	BTR1.2	TSEG1.2	Time Segment 1.2	X	X
	BTR1.1	TSEG1.1	Time Segment 1.1	X	X
	BTR1.0	TSEG1.0	Time Segment 1.0	X	X
Output control	OC.7	OCTP1	Output Control Transistor P1	X	X
	OC.6	OCTN1	Output Control Transistor N1	X	X
	OC.5	OCPOL1	Output Control Polarity 1	X	X
	OC.4	OCTP0	Output Control Transistor P0	X	X
	OC.3	OCTN0	Output Control Transistor N0	X	X
	OC.2	OCPOL0	Output Control Polarity 0	X	X
	OC.1	OCMODE1	Output Control Mode 1	X	X
	OC.0	OCMODE0	Output Control Mode 0	X	X
Transmit buffer	–	TXB	Transmit Buffer	X	X
Receive buffer	–	RXB	Receive Buffer	X; note 5	X; note 5
Clock divider	–	CDR	Clock Divider Register	00000000 (Intel); 00000101 (Motorola)	X

Stand-alone CAN controller

SJA1000

Notes

1. X means that the value of these registers or bits is not influenced.
2. Remarks in brackets explain functional meaning.
3. Reading the command register will always reflect a binary '11111111'.
4. On bus-off the error interrupt is set, if enabled.
5. Internal read/write pointers of the RXFIFO are reset to their initial values. A subsequent read access to the RXB would show undefined data values (parts of old messages). If a message is transmitted, this message is written in parallel to the receive buffer but no receive interrupt is generated and the receive buffer area is not locked. So, even if the receive buffer is empty, the last transmitted message may be read from the receive buffer until it is overridden by the next received or transmitted message.
Upon a hardware reset, the RXFIFO pointers are reset to the physical RAM address '0'. Setting CR.0 by software or due to the bus-off event will reset the RXFIFO pointers to the currently valid FIFO start address which is different from the RAM address '0' after the first release receive buffer command.

6.3.3 CONTROL REGISTER (CR)

The contents of the control register are used to change the behaviour of the CAN controller. Bits may be set or reset by the attached microcontroller which uses the control register as a read/write memory.

Table 3 Bit interpretation of the control register (CR); CAN address 0

BIT	SYMBOL	NAME	VALUE	FUNCTION
CR.7	–	–	–	reserved; note 1
CR.6	–	–	–	reserved; note 2
CR.5	–	–	–	reserved; note 3
CR.4	OIE	Overrun Interrupt Enable	1	enabled; if the data overrun bit is set, the microcontroller receives an overrun interrupt signal (see also status register; Table 5)
			0	disabled; the microcontroller receives no overrun interrupt signal from the SJA1000
CR.3	EIE	Error Interrupt Enable	1	enabled; if the error or bus status change, the microcontroller receives an error interrupt signal (see also status register; Table 5)
			0	disabled; the microcontroller receives no error interrupt signal from the SJA1000
CR.2	TIE	Transmit Interrupt Enable	1	enabled; when a message has been successfully transmitted or the transmit buffer is accessible again, (e.g. after an abort transmission command) the SJA1000 transmits a transmit interrupt signal to the microcontroller
			0	disabled; the microcontroller receives no transmit interrupt signal from the SJA1000

Stand-alone CAN controller

SJA1000

BIT	SYMBOL	NAME	VALUE	FUNCTION
CR.1	RIE	Receive Interrupt Enable	1	enabled; when a message has been received without errors, the SJA1000 transmits a receive interrupt signal to the microcontroller
			0	disabled; the microcontroller receives no transmit interrupt signal from the SJA1000
CR.0	RR	Reset Request; note 4	1	present; detection of a reset request results in aborting the current transmission/reception of a message and entering the reset mode
			0	absent; on the '1-to-0' transition of the reset request bit, the SJA1000 returns to the operating mode

Notes

1. Any write access to the control register has to set this bit to logic 0 (reset value is logic 0).
2. In the PCA82C200 this bit was used to select the synchronization mode. Because this mode is not longer implemented, setting this bit has no influence on the microcontroller. Due to software compatibility setting this bit is allowed. This bit will not change after hardware or software reset. In addition the value written by users software is reflected.
3. Reading this bit will always reflect a logic 1.
4. During a hardware reset or when the bus status bit is set to logic 1 (bus-off), the reset request bit is set to logic 1 (present). If this bit is accessed by software, a value change will become visible and takes effect first with the next positive edge of the internal clock which operates with $\frac{1}{2}$ of the external oscillator frequency. During an external reset the microcontroller cannot set the reset request bit to logic 0 (absent). Therefore, after having set the reset request bit to logic 0, the microcontroller must check this bit to ensure that the external reset pin is not being held LOW. Changes of the reset request bit are synchronized with the internal divided clock. Reading the reset request bit reflects the synchronized status.
After the reset request bit is set to logic 0 the SJA1000 will wait for:
 - a) One occurrence of bus-free signal (11 recessive bits), if the preceding reset request has been caused by a hardware reset or a CPU-initiated reset
 - b) 128 occurrences of bus-free, if the preceding reset request has been caused by a CAN controller initiated bus-off, before re-entering the bus-on mode; it should be noted that several registers are modified if the reset request bit was set (see also Table 2).

6.3.4 COMMAND REGISTER (CMR)

A command bit initiates an action within the transfer layer of the SJA1000. The command register appears to the microcontroller as a write only memory. If a read access is performed to this address the byte '11111111' is returned. Between two commands at least one internal clock cycle is needed to process. The internal clock is divided by two from the external oscillator frequency.

Stand-alone CAN controller

SJA1000

Table 4 Bit interpretation of the command register (CMR); CAN address 1

BIT	SYMBOL	NAME	VALUE	FUNCTION
CMR.7	–	–	–	reserved
CMR.6	–	–	–	reserved
CMR.5	–	–	–	reserved
CMR.4	GTS	Go To Sleep; note 1	1	sleep; the SJA1000 enters sleep mode if no CAN interrupt is pending and there is no bus activity
			0	wake up; SJA1000 operates normal
CMR.3	CDO	Clear Data Overrun; note 2	1	clear; data overrun status bit is cleared
			0	no action
CMR.2	RRB	Release Receive Buffer; note 3	1	released; the receive buffer, representing the message memory space in the RXFIFO is released
			0	no action
CMR.1	AT	Abort Transmission; note 4	1	present; if not already in progress, a pending transmission request is cancelled
			0	absent; no action
CMR.0	TR	Transmission Request; note 5	1	present; a message will be transmitted
			0	absent; no action

Notes

1. The SJA1000 will enter sleep mode if the sleep bit is set to logic 1 (sleep); there is no bus activity and no interrupt is pending. Setting of GTS with at least one of the previously mentioned exceptions valid will result in a wake-up interrupt. After sleep mode is set, the CLKOUT signal continues until at least 15 bit times have passed, to allow a host microcontroller clocked via this signal to enter its own standby mode before the CLKOUT goes LOW. The SJA1000 will wake up when one of the three previously mentioned conditions is negated: after 'Go To Sleep' is set LOW (wake-up), there is bus activity or $\overline{\text{INT}}$ is driven LOW (active). On wake-up, the oscillator is started and a wake-up interrupt is generated. A sleeping SJA1000 which wakes up due to bus activity will not be able to receive this message until it detects 11 consecutive recessive bits (bus-free sequence). It should be noted that setting of GTS is not possible in reset mode. After clearing of reset request, setting of GTS is possible first, when bus-free is detected again.
2. This command bit is used to clear the data overrun condition indicated by the data overrun status bit. As long as the data overrun status bit is set no further data overrun interrupt is generated. It is allowed to give the clear data overrun command at the same time as a release receive buffer command.
3. After reading the contents of the receive buffer, the microcontroller can release this memory space of the RXFIFO by setting the release receive buffer bit to logic 1. This may result in another message becoming immediately available within the receive buffer. This event will force another receive interrupt, if enabled. If there is no other message available no further receive interrupt is generated and the receive buffer status bit is cleared.
4. The abort transmission bit is used when the CPU requires the suspension of the previously requested transmission, e.g. to transmit a more urgent message before. A transmission already in progress is not stopped. In order to see if the original message had been either transmitted successfully or aborted, the transmission complete status bit should be checked. This should be done after the transmit buffer status bit has been set to logic 1 (released) or a transmit interrupt has been generated.
5. If the transmission request was set to logic 1 in a previous command, it cannot be cancelled by setting the transmission request bit to logic 0. The requested transmission may be cancelled by setting the abort transmission bit to logic 1.

Stand-alone CAN controller

SJA1000

6.3.5 STATUS REGISTER (SR)

The content of the status register reflects the status of the SJA1000. The status register appears to the microcontroller as a read only memory.

Table 5 Bit interpretation of the status register (SR); CAN address 2

BIT	SYMBOL	NAME	VALUE	FUNCTION
SR.7	BS	Bus Status; note 1	1	bus-off; the SJA1000 is not involved in bus activities
			0	bus-on; the SJA1000 is involved in bus activities
SR.6	ES	Error Status; note 2	1	error; at least one of the error counters has reached or exceeded the CPU warning limit
			0	ok; both error counters are below the warning limit
SR.5	TS	Transmit Status; note 3	1	transmit; the SJA1000 is transmitting a message
			0	idle; no transmit message is in progress
SR.4	RS	Receive Status; note 3	1	receive; the SJA1000 is receiving a message
			0	idle; no receive message is in progress
SR.3	TCS	Transmission Complete Status; note 4	1	complete; the last requested transmission has been successfully completed
			0	incomplete; the previously requested transmission is not yet completed
SR.2	TBS	Transmit Buffer Status; note 5	1	released; the CPU may write a message into the transmit buffer
			0	locked; the CPU cannot access the transmit buffer; a message is waiting for transmission or is already in process
SR.1	DOS	Data Overrun Status; note 6	1	overrun; a message was lost because there was not enough space for that message in the RXFIFO
			0	absent; no data overrun has occurred since the last clear data overrun command was given
SR.0	RBS	Receive Buffer Status; note 7	1	full; one or more messages are available in the RXFIFO
			0	empty; no message is available

Stand-alone CAN controller

SJA1000

Notes

1. When the transmit error counter exceeds the limit of 255 [the bus status bit is set to logic 1 (bus-off)] the CAN controller will set the reset request bit to logic 1 (present) and an error interrupt is generated, if enabled. It will stay in this mode until the CPU clears the reset request bit. Once this is completed the CAN controller will wait the minimum protocol-defined time (128 occurrences of the bus-free signal). After that the bus status bit is cleared (bus-on), the error status bit is set to logic 0 (ok), the error counters are reset and an error interrupt is generated, if enabled.
2. Errors detected during reception or transmission will affect the error counters according to the CAN 2.0B protocol specification. The error status bit is set when at least one of the error counters has reached or exceeded the CPU warning limit of 96. An error interrupt is generated, if enabled.
3. If both the receive status and the transmit status bits are logic 0 (idle) the CAN-bus is idle.
4. The transmission complete status bit is set to logic 0 (incomplete) whenever the transmission request bit is set to logic 1. The transmission complete status bit will remain at logic 0 (incomplete) until a message is transmitted successfully.
5. If the CPU tries to write to the transmit buffer when the transmit buffer status bit is at logic 0 (locked), the written byte will not be accepted and will be lost without being indicated.
6. When a message that shall be received has passed the acceptance filter successfully (i.e. earliest after arbitration field), the CAN controller needs space in the RXFIFO to store the message descriptor. Accordingly there must be enough space for each data byte which has been received. If there is not enough space to store the message, that message will be dropped and the data overrun condition will be indicated to the CPU only, if this received message has no errors until the last but one bit of end of frame (message becomes valid).
7. After reading a message stored in the RXFIFO and releasing this memory space with the command release receive buffer, this bit is cleared. If there is another message available within the FIFO this bit is set again with the next bit quantum (t_{scl}).

Stand-alone CAN controller

SJA1000

6.3.6 INTERRUPT REGISTER (IR)

The interrupt register allows the identification of an interrupt source. When one or more bits of this register are set, the $\overline{\text{INT}}$ pin is activated (LOW). After this register is read by the microcontroller, all bits are reset what results in a floating level at $\overline{\text{INT}}$. The interrupt register appears to the microcontroller as a read only memory.

Table 6 Bit interpretation of the interrupt register (IR); CAN address 3

BIT	SYMBOL	NAME	VALUE	FUNCTION
IR.7	–	–	–	reserved; note 1
IR.6	–	–	–	reserved; note 1
IR.5	–	–	–	reserved; note 1
IR.4	WUI	Wake-Up Interrupt; note 2	1	set; this bit is set when the sleep mode is left
			0	reset; this bit is cleared by any read access of the microcontroller
IR.3	DOI	Data Overrun Interrupt; note 3	1	set; this bit is set on a '0-to-1' transition of the data overrun status bit, when the data overrun interrupt enable is set to logic 1 (enabled)
			0	reset; this bit is cleared by any read access of the microcontroller
IR.2	EI	Error Interrupt	1	set; this bit is set on a change of either the error status or bus status bits if the error interrupt enable is set to logic 1 (enabled)
			0	reset; this bit is cleared by any read access of the microcontroller
IR.1	TI	Transmit Interrupt	1	set; this bit is set whenever the transmit buffer status changes from logic 0 to logic 1 (released) and transmit interrupt enable is set to logic 1 (enabled)
			0	reset; this bit is cleared by any read access of the microcontroller
IR.0	RI	Receive Interrupt; note 4	1	set; this bit is set while the receive FIFO is not empty and the receive interrupt enable bit is set to logic 1 (enabled)
			0	reset; this bit is cleared by any read access of the microcontroller

Notes

1. Reading this bit will always reflect a logic 1.
2. A wake-up interrupt is also generated if the CPU tries to set go to sleep while the CAN controller is involved in bus activities or a CAN interrupt is pending.
3. The overrun interrupt bit (if enabled) and the data overrun status bit are set at the same time.
4. The receive interrupt bit (if enabled) and the receive buffer status bit are set at the same time.
It should be noted that the receive interrupt bit is cleared upon a read access, even if there is another message available within the FIFO. The moment the release receive buffer command is given and there is another message valid within the receive buffer, the receive interrupt is set again (if enabled) with the next t_{sc1} .

Stand-alone CAN controller

SJA1000

6.3.7 TRANSMIT BUFFER LAYOUT

The global layout of the transmit buffer is shown in Table 7. The buffer serves to store a message from the microcontroller to be transmitted by the SJA1000. It is subdivided into a descriptor and data field. The transmit buffer can be written to and read out by the microcontroller in operating mode only. In reset mode a 'FFH' is reflected for all bytes.

Table 7 Layout of transmit buffer

CAN ADDRESS	FIELD	NAME	BITS							
			7	6	5	4	3	2	1	0
10	descriptor	identifier byte 1	ID.10	ID.9	ID.8	ID.7	ID.6	ID.5	ID.4	ID.3
11		identifier byte 2	ID.2	ID.1	ID.0	RTR	DLC.3	DLC.2	DLC.1	DLC.0
12	data	TX data 1	transmit data byte 1							
13		TX data 2	transmit data byte 2							
14		TX data 3	transmit data byte 3							
15		TX data 4	transmit data byte 4							
16		TX data 5	transmit data byte 5							
17		TX data 6	transmit data byte 6							
18		TX data 7	transmit data byte 7							
19		TX data 8	transmit data byte 8							

6.3.7.1 Identifier (ID)

The identifier consists of 11 bits (ID.10 to ID.0). ID.10 is the most significant bit, which is transmitted first on the bus during the arbitration process. The identifier acts as the message's name. It is used in a receiver for acceptance filtering and also determining the bus access priority during the arbitration process. The lower the binary value of the identifier the higher the priority. This is due to a larger number of leading dominant bits during arbitration.

6.3.7.2 Remote Transmission Request (RTR)

If this bit is set, a remote frame will be transmitted via the bus. This means that no data bytes are included within this frame. Nevertheless, it is necessary to specify the correct data length code which depends on the corresponding data frame with the same identifier coding.

If the RTR bit is not set, a data frame will be sent including the number of data bytes as specified by the data length code.

6.3.7.3 Data Length Code (DLC)

The number of bytes in the data field of a message is coded by the data length code. At the start of a remote frame transmission the data length code is not considered due to the RTR bit being at logic 1 (remote). This forces the number of transmitted/received data bytes to be logic 0. Nevertheless, the data length code must be

specified correctly to avoid bus errors if two CAN controllers start a remote frame transmission with the same identifier simultaneously.

The range of the data byte count is 0 to 8 bytes and is coded as follows:

$$\text{DataByteCount} = 8 \times \text{DLC.3} + 4 \times \text{DLC.2} + 2 \times \text{DLC.1} + \text{DLC.0}$$

For reasons of compatibility no data length code >8 should be used. If a value >8 is selected, 8 bytes are transmitted in the data frame with the data length code specified in DLC.

6.3.7.4 Data field

The number of transferred data bytes is determined by the data length code. The first bit transmitted is the most significant bit of data byte 1 at address 12.

6.3.8 RECEIVE BUFFER

The global layout of the receive buffer is very similar to the transmit buffer described in Section 6.3.7. The receive buffer is the accessible part of the RXFIFO and is located in the range between CAN address 20 and 29.

Stand-alone CAN controller

SJA1000

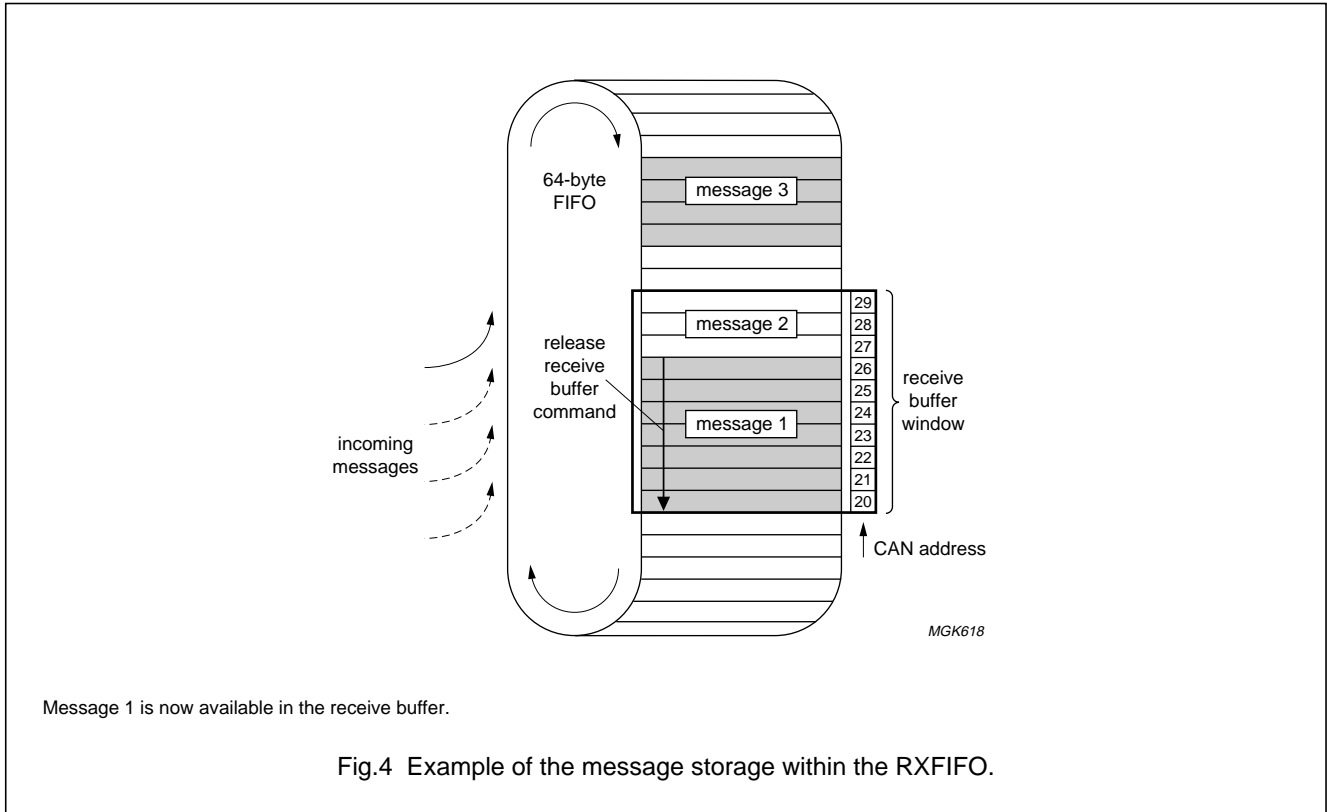

Identifier, remote transmission request bit and data length code have the same meaning and location as described in the transmit buffer but within the address range 20 to 29.

As illustrated in Fig.4 the RXFIFO has space for 64 message bytes in total. The number of messages that can be stored in the FIFO at any particular moment depends on the length of the individual messages. If there is not enough space for a new message within the RXFIFO, the CAN controller generates a data overrun condition. A message which is partly written into the RXFIFO, when the data overrun condition occurs, is deleted. This situation is indicated to the microcontroller via the status register and the data overrun interrupt, if enabled and the frame was received without any errors until the last but one bit of end of frame (RX message becomes valid).

6.3.9 ACCEPTANCE FILTER

With the help of the acceptance filter the CAN controller is able to allow passing of received messages to the RXFIFO only when the identifier bits of the received message are equal to the predefined ones within the acceptance filter registers. The acceptance filter is defined by the acceptance code register (ACR; see Section 6.3.9.1) and the acceptance mask register (AMR; see Section 6.3.9.2).

Stand-alone CAN controller

SJA1000

6.3.9.1 Acceptance Code Register (ACR)

Table 8 ACR bit allocation; can address 4

BIT 7	BIT 6	BIT 5	BIT 4	BIT 3	BIT 2	BIT 1	BIT 0
AC.7	AC.6	AC.5	AC.4	AC.3	AC.2	AC.1	AC.0

This register can be accessed (read/write), if the reset request bit is set HIGH (present). When a message is received which passes the acceptance test and there is receive buffer space left, then the respective descriptor and data field are sequentially stored in the RXFIFO. When the complete message has been correctly received the following occurs:

- The receive status bit is set HIGH (full)
- If the receive interrupt enable bit is set HIGH (enabled), the receive interrupt is set HIGH (set).

6.3.9.2 Acceptance Mask Register (AMR)

Table 9 AMR bit allocation; CAN address 5

BIT 7	BIT 6	BIT 5	BIT 4	BIT 3	BIT 2	BIT 1	BIT 0
AM.7	AM.6	AM.5	AM.4	AM.3	AM.2	AM.1	AM.0

This register can be accessed (read/write), if the reset request bit is set HIGH (present). The acceptance mask register qualifies which of the corresponding bits of the acceptance code are 'relevant' (AM.X = 0) or 'don't care' (AM.X = 1) for acceptance filtering.

6.3.9.3 Other registers

The other registers are described in Section 6.5.

The acceptance code bits (AC.7 to AC.0) and the eight most significant bits of the message's identifier (ID.10 to ID.3) must be equal to those bit positions which are marked relevant by the acceptance mask bits (AM.7 to AM.0). If the conditions as described in the following equation are fulfilled, acceptance is given:

$$(ID.10 \text{ to } ID.3) \equiv (AC.7 \text{ to } AC.0) \vee (AM.7 \text{ to } AM.0) \\ \equiv 11111111$$

6.4 PeliCAN mode

6.4.1 PELICAN ADDRESS LAYOUT

The CAN controller's internal registers appear to the CPU as on-chip memory mapped peripheral registers. Because the CAN controller can operate in different modes (operating/reset; see also Section 6.4.3), one has to distinguish between different internal address definitions.

Starting from CAN address 32 the complete internal RAM (80-byte) is mapped to the CPU interface.

Stand-alone CAN controller

SJA1000

Table 10 PeliCAN address allocation; note 1

CAN ADDRESS	OPERATING MODE				RESET MODE	
	READ		WRITE		READ	WRITE
0	mode		mode		mode	mode
1	(00H)		command		(00H)	command
2	status		–		status	–
3	interrupt		–		interrupt	–
4	interrupt enable		interrupt enable		interrupt enable	interrupt enable
5	reserved (00H)		–		reserved (00H)	–
6	bus timing 0		–		bus timing 0	bus timing 0
7	bus timing 1		–		bus timing 1	bus timing 1
8	output control		–		output control	output control
9	test		test; note 2		test	test; note 2
10	reserved (00H)		–		reserved (00H)	–
11	arbitration lost capture		–		arbitration lost capture	–
12	error code capture		–		error code capture	–
13	error warning limit		–		error warning limit	error warning limit
14	RX error counter		–		RX error counter	RX error counter
15	TX error counter		–		TX error counter	TX error counter
16	RX frame information SFF; note 3	RX frame information EFF; note 4	TX frame information SFF; note 3	TX frame information EFF; note 4	acceptance code 0	acceptance code 0
17	RX identifier 1	RX identifier 1	TX identifier 1	TX identifier 1	acceptance code 1	acceptance code 1
18	RX identifier 2	RX identifier 2	TX identifier 2	TX identifier 2	acceptance code 2	acceptance code 2
19	RX data 1	RX identifier 3	TX data 1	TX identifier 3	acceptance code 3	acceptance code 3
20	RX data 2	RX identifier 4	TX data 2	TX identifier 4	acceptance mask 0	acceptance mask 0
21	RX data 3	RX data 1	TX data 3	TX data 1	acceptance mask 1	acceptance mask 1
22	RX data 4	RX data 2	TX data 4	TX data 2	acceptance mask 2	acceptance mask 2
23	RX data 5	RX data 3	TX data 5	TX data 3	acceptance mask 3	acceptance mask 3
24	RX data 6	RX data 4	TX data 6	TX data 4	reserved (00H)	–
25	RX data 7	RX data 5	TX data 7	TX data 5	reserved (00H)	–
26	RX data 8	RX data 6	TX data 8	TX data 6	reserved (00H)	–

Stand-alone CAN controller

SJA1000

CAN ADDRESS	OPERATING MODE				RESET MODE	
	READ		WRITE		READ	WRITE
27	(FIFO RAM); note 5	RX data 7	–	TX data 7	reserved (00H)	–
28	(FIFO RAM); note 5	RX data 8	–	TX data 8	reserved (00H)	–
29	RX message counter		–		RX message counter	–
30	RX buffer start address		–		RX buffer start address	RX buffer start address
31	clock divider		clock divider; note 6		clock divider	clock divider
32	internal RAM address 0 (FIFO)		–		internal RAM address 0	internal RAM address 0
33	internal RAM address 1 (FIFO)		–		internal RAM address 1	internal RAM address 1
↓	↓		↓		↓	↓
95	internal RAM address 63 (FIFO)		–		internal RAM address 63	internal RAM address 63
96	internal RAM address 64 (TX buffer)		–		internal RAM address 64	internal RAM address 64
↓	↓		↓		↓	↓
108	internal RAM address 76 (TX buffer)		–		internal RAM address 76	internal RAM address 76
109	internal RAM address 77 (free)		–		internal RAM address 77	internal RAM address 77
110	internal RAM address 78 (free)		–		internal RAM address 78	internal RAM address 78
111	internal RAM address 79 (free)		–		internal RAM address 79	internal RAM address 79
112	(00H)		–		(00H)	–
↓	↓		↓		↓	↓
127	(00H)		–		(00H)	–

Notes

1. It should be noted that the registers are repeated within higher CAN address areas (the most significant bit of the 8-bit CPU address is not decoded: CAN address 128 continues with CAN address 0 and so on).
2. Test register is used for production testing only. Using this register during normal operation may result in undesired behaviour of the device.
3. SFF = Standard Frame Format.
4. EFF = Extended Frame Format.
5. These address allocations reflect the FIFO RAM space behind the current message. The contents are random after power-up and contain the beginning of the next message which is received after the current one. If no further message is received, parts of old messages may occur here.
6. Some bits are writeable in reset mode only (CAN mode, CBP, RXINTEN and clock off).

Stand-alone CAN controller

SJA1000

6.4.2 RESET VALUES

Detection of a set reset mode bit results in aborting the current transmission/reception of a message and entering the reset mode. On the '1-to-0' transition of the reset mode bit, the CAN controller returns to the mode defined within the mode register.

Table 11 Reset mode configuration; notes 1 and 2

REGISTER	BIT	SYMBOL	NAME	VALUE	
				RESET BY HARDWARE	SETTING MOD.0 BY SOFTWARE OR DUE TO BUS-OFF
Mode	MOD.7 to 5	–	reserved	0 (reserved)	0 (reserved)
	MOD.4	SM	Sleep Mode	0 (wake-up)	0 (wake-up)
	MOD.3	AFM	Acceptance Filter Mode	0 (dual)	X
	MOD.2	STM	Self Test Mode	0 (normal)	X
	MOD.1	LOM	Listen Only Mode	0 (normal)	X
	MOD.0	RM	Reset Mode	1 (present)	1 (present)
Command	CMR.7 to 5	–	reserved	0 (reserved)	0 (reserved)
	CMR.4	SRR	Self Reception Request	0 (absent)	0 (absent)
	CMR.3	CDO	Clear Data Overrun	0 (no action)	0 (no action)
	CMR.2	RRB	Release Receive Buffer	0 (no action)	0 (no action)
	CMR.1	AT	Abort Transmission	0 (absent)	0 (absent)
	CMR.0	TR	Transmission Request	0 (absent)	0 (absent)
Status	SR.7	BS	Bus Status	0 (bus-on)	X
	SR.6	ES	Error Status	0 (ok)	X
	SR.5	TS	Transmit Status	1 (wait idle)	1 (wait idle)
	SR.4	RS	Receive Status	1 (wait idle)	1 (wait idle)
	SR.3	TCS	Transmission Complete Status	1 (complete)	X
	SR.2	TBS	Transmit Buffer Status	1 (released)	1 (released)
	SR.1	DOS	Data Overrun Status	0 (absent)	0 (absent)
	SR.0	RBS	Receive Buffer Status	0 (empty)	0 (empty)
Interrupt	IR.7	BEI	Bus Error Interrupt	0 (reset)	0 (reset)
	IR.6	ALI	Arbitration Lost Interrupt	0 (reset)	0 (reset)
	IR.5	EPI	Error Passive Interrupt	0 (reset)	0 (reset)
	IR.4	WUI	Wake-Up Interrupt	0 (reset)	0 (reset)
	IR.3	DOI	Data Overrun Interrupt	0 (reset)	0 (reset)
	IR.2	EI	Error Warning Interrupt	0 (reset)	X; note 3
	IR.1	TI	Transmit Interrupt	0 (reset)	0 (reset)
	IR.0	RI	Receive Interrupt	0 (reset)	0 (reset)

Stand-alone CAN controller

SJA1000

REGISTER	BIT	SYMBOL	NAME	VALUE	
				RESET BY HARDWARE	SETTING MOD.0 BY SOFTWARE OR DUE TO BUS-OFF
Interrupt enable	IER.7	BEIE	Bus Error Interrupt Enable	X	X
	IER.6	ALIE	Arbitration Lost Interrupt Enable	X	X
	IER.5	EPIE	Error Passive Interrupt Enable	X	X
	IER.4	WUIE	Wake-Up Interrupt Enable	X	X
	IER.3	DOIE	Data Overrun Interrupt Enable	X	X
	IER.2	EIE	Error Warning Interrupt Enable	X	X
	IER.1	TIE	Transmit Interrupt Enable	X	X
	IER.0	RIE	Receive Interrupt Enable	X	X
Bus timing 0	BTR0.7	SJW.1	Synchronization Jump Width 1	X	X
	BTR0.6	SJW.0	Synchronization Jump Width 0	X	X
	BTR0.5	BRP.5	Baud Rate Prescaler 5	X	X
	BTR0.4	BRP.4	Baud Rate Prescaler 4	X	X
	BTR0.3	BRP.3	Baud Rate Prescaler 3	X	X
	BTR0.2	BRP.2	Baud Rate Prescaler 2	X	X
	BTR0.1	BRP.1	Baud Rate Prescaler 1	X	X
	BTR0.0	BRP.0	Baud Rate Prescaler 0	X	X
Bus timing 1	BTR1.7	SAM	Sampling	X	X
	BTR1.6	TSEG2.2	Time Segment 2.2	X	X
	BTR1.5	TSEG2.1	Time Segment 2.1	X	X
	BTR1.4	TSEG2.0	Time Segment 2.0	X	X
	BTR1.3	TSEG1.3	Time Segment 1.3	X	X
	BTR1.2	TSEG1.2	Time Segment 1.2	X	X
	BTR1.1	TSEG1.1	Time Segment 1.1	X	X
	BTR1.0	TSEG1.0	Time Segment 1.0	X	X

Stand-alone CAN controller

SJA1000

REGISTER	BIT	SYMBOL	NAME	VALUE	
				RESET BY HARDWARE	SETTING MOD.0 BY SOFTWARE OR DUE TO BUS-OFF
Output control	OCR.7	OCTP1	Output Control Transistor P1	X	X
	OCR.6	OCTN1	Output Control Transistor N1	X	X
	OCR.5	OCPOL1	Output Control Polarity 1	X	X
	OCR.4	OCTP0	Output Control Transistor P0	X	X
	OCR.3	OCTN0	Output Control Transistor N0	X	X
	OCR.2	OCPOL0	Output Control Polarity 0	X	X
	OCR.1	OCMODE1	Output Control Mode 1	X	X
	OCR.0	OCMODE0	Output Control Mode 0	X	X
Arbitration lost capture	–	ALC	Arbitration Lost Capture	0	X
Error code capture	–	ECC	Error Code Capture	0	X
Error warning limit	–	EWLR	Error Warning Limit Register	96	X
RX error counter	–	RXERR	Receive Error Counter	0 (reset)	X; note 4
TX error counter	–	TXERR	Transmit Error Counter	0 (reset)	X; note 4
TX buffer	–	TXB	Transmit Buffer	X	X
RX buffer	–	RXB	Receive Buffer	X; note 5	X; note 5
ACR 0 to 3	–	ACR0 to ACR3	Acceptance Code Registers	X	X
AMR 0 to 3	–	AMR0 to AMR3	Acceptance Mask Registers	X	X
RX message counter	–	RMC	RX Message Counter	0	0
RX buffer start address	–	RBSA	RX Buffer Start Address	00000000	X
Clock divider	–	CDR	Clock Divider Register	00000000 Intel; 00000101 Motorola	X

Stand-alone CAN controller

SJA1000

Notes

1. X means that the value of these registers or bits is not influenced.
2. Remarks in brackets explain functional meaning.
3. On bus-off the error warning interrupt is set, if enabled.
4. If the reset mode was entered due to a bus-off condition, the receive error counter is cleared and the transmit error counter is initialized to 127 to count-down the CAN-defined bus-off recovery time consisting of 128 occurrences of 11 consecutive recessive bits.
5. Internal read/write pointers of the RXFIFO are reset to their initial values. A subsequent read access to the RXB would show undefined data values (parts of old messages).
If a message is transmitted, this message is written in parallel to the receive buffer. A receive interrupt is generated only if this transmission was forced by the self reception request. So, even if the receive buffer is empty, the last transmitted message may be read from the receive buffer until it is overwritten by the next received or transmitted message.
Upon a hardware reset, the RXFIFO pointers are reset to the physical RAM address '0'. Setting CR.0 by software or due to the bus-off event will reset the RXFIFO pointers to the currently valid FIFO start address (RBSA register) which is different from the RAM address '0' after the first release receive buffer command.

6.4.3 MODE REGISTER (MOD)

The contents of the mode register are used to change the behaviour of the CAN controller. Bits may be set or reset by the CPU which uses the control register as a read/write memory. Reserved bits are read as logic 0.

Table 12 Bit interpretation of the mode register (MOD); CAN address '0'

BIT	SYMBOL	NAME	VALUE	FUNCTION
MOD.7	–	–	–	reserved
MOD.6	–	–	–	reserved
MOD.5	–	–	–	reserved
MOD.4	SM	Sleep Mode; note 1	1	sleep; the CAN controller enters sleep mode if no CAN interrupt is pending and if there is no bus activity
			0	wake-up; the CAN controller wakes up if sleeping
MOD.3	AFM	Acceptance Filter Mode; note 2	1	single; the single acceptance filter option is enabled (one filter with the length of 32 bit is active)
			0	dual; the dual acceptance filter option is enabled (two filters, each with the length of 16 bit are active)
MOD.2	STM	Self Test Mode; note 2	1	self test; in this mode a full node test is possible without any other active node on the bus using the self reception request command; the CAN controller will perform a successful transmission, even if there is no acknowledge received
			0	normal; an acknowledge is required for successful transmission

Stand-alone CAN controller

SJA1000

BIT	SYMBOL	NAME	VALUE	FUNCTION
MOD.1	LOM	Listen Only Mode; notes 2 and 3	1	listen only; in this mode the CAN controller would give no acknowledge to the CAN-bus, even if a message is received successfully; the error counters are stopped at the current value
			0	normal
MOD.0	RM	Reset Mode; note 4	1	reset; detection of a set reset mode bit results in aborting the current transmission/reception of a message and entering the reset mode
			0	normal; on the '1-to-0' transition of the reset mode bit, the CAN controller returns to the operating mode

Notes

1. The SJA1000 will enter sleep mode if the sleep mode bit is set to logic 1 (sleep); then there is no bus activity and no interrupt is pending. Setting of SM with at least one of the previously mentioned exceptions valid will result in a wake-up interrupt. After sleep mode is set, the CLKOUT signal continues until at least 15 bit times have passed, to allow a host microcontroller clocked via this signal to enter its own standby mode before the CLKOUT goes LOW. The SJA1000 will wake up when one of the three previously mentioned conditions is negated: after SM is set LOW (wake-up), there is bus activity or $\overline{\text{INT}}$ is driven LOW (active). On wake-up, the oscillator is started and a wake-up interrupt is generated. A sleeping SJA1000 which wakes up due to bus activity will not be able to receive this message until it detects 11 consecutive recessive bits (bus-free sequence). It should be noted that setting of SM is not possible in reset mode. After clearing of reset mode, setting of SM is possible first, when bus-free is detected again.
2. A write access to the bits MOD.1 to MOD.3 is only possible, if the reset mode is entered previously.
3. This mode of operation forces the CAN controller to be error passive. Message transmission is not possible. The listen only mode can be used e.g. for software driven bit rate detection and 'hot plugging'. All other functions can be used like in normal mode.
4. During a hardware reset or when the bus status bit is set to logic 1 (bus-off), the reset mode bit is also set to logic 1 (present). If this bit is accessed by software, a value change will become visible and takes effect first with the next positive edge of the internal clock which operates at half of the external oscillator frequency. During an external reset the microcontroller cannot set the reset mode bit to logic 0 (absent). Therefore, after having set the reset mode bit to logic 1, the microcontroller must check this bit to ensure that the external reset pin is not being held HIGH. Changes of the reset request bit are synchronized with the internal divided clock. Reading the reset request bit reflects the synchronized status. After the reset mode bit is set to logic 0 the CAN controller will wait for:
 - a) One occurrence of bus-free signal (11 recessive bits), if the preceding reset has been caused by a hardware reset or a CPU-initiated reset.
 - b) 128 occurrences of bus-free, if the preceding reset has been caused by a CAN controller initiated bus-off, before re-entering the bus-on mode.

Stand-alone CAN controller

SJA1000

6.4.4 COMMAND REGISTER (CMR)

A command bit initiates an action within the transfer layer of the CAN controller. This register is write only, all bits will return a logic 0 when being read. Between two commands at least one internal clock cycle is needed in order to proceed. The internal clock is half of the external oscillator frequency.

Table 13 Bit interpretation of the command register (CMR); CAN address 1

BIT	SYMBOL	NAME	VALUE	FUNCTION
CMR.7	–	reserved	–	–
CMR.6	–	reserved	–	–
CMR.5	–	reserved	–	–
CMR.4	SRR	Self Reception Request; notes 1 and 2	1	present; a message shall be transmitted and received simultaneously
			0	– (absent)
CMR.3	CDO	Clear Data Overrun; note 3	1	clear; the data overrun status bit is cleared
			0	– (no action)
CMR.2	RRB	Release Receive Buffer; note 4	1	released; the receive buffer, representing the message memory space in the RXFIFO is released
			0	– (no action)
CMR.1	AT	Abort Transmission; notes 5 and 2	1	present; if not already in progress, a pending transmission request is cancelled
			0	– (absent)
CMR.0	TR	Transmission Request; notes 6 and 2	1	present; a message shall be transmitted
			0	– (absent)

Notes

1. Upon self reception request a message is transmitted and simultaneously received if the acceptance filter is set to the corresponding identifier. A receive and a transmit interrupt will indicate correct self reception (see also self test mode in mode register).
2. Setting the command bits CMR.0 and CMR.1 simultaneously results in sending the transmit message once. No re-transmission will be performed in the event of an error or arbitration lost (single-shot transmission). Setting the command bits CMR.4 and CMR.1 simultaneously results in sending the transmit message once using the self reception feature. No re-transmission will be performed in the event of an error or arbitration lost. Setting the command bits CMR.0, CMR.1 and CMR.4 simultaneously results in sending the transmit message once as described for CMR.0 and CMR.1. The moment the transmit status bit is set within the status register, the internal transmission request bit is cleared automatically. Setting CMR.0 and CMR.4 simultaneously will ignore the set CMR.4 bit.
3. This command bit is used to clear the data overrun condition indicated by the data overrun status bit. As long as the data overrun status bit is set no further data overrun interrupt is generated.
4. After reading the contents of the receive buffer, the CPU can release this memory space in the RXFIFO by setting the release receive buffer bit to logic 1. This may result in another message becoming immediately available within the receive buffer. If there is no other message available, the receive interrupt bit is reset.

Stand-alone CAN controller

SJA1000

5. The abort transmission bit is used when the CPU requires the suspension of the previously requested transmission, e.g. to transmit a more urgent message before. A transmission already in progress is not stopped. In order to see if the original message has been either transmitted successfully or aborted, the transmission complete status bit should be checked. This should be done after the transmit buffer status bit has been set to logic 1 or a transmit interrupt has been generated.

It should be noted that a transmit interrupt is generated even if the message was aborted because the transmit buffer status bit changes to 'released'.

6. If the transmission request was set to logic 1 in a previous command, it cannot be cancelled by setting the transmission request bit to logic 0. The requested transmission may be cancelled by setting the abort transmission bit to logic 1.

6.4.5 STATUS REGISTER (SR)

The content of the status register reflects the status of the CAN controller. The status register appears to the CPU as a read only memory.

Table 14 Bit interpretation of the status register (SR); CAN address 2

BIT	SYMBOL	NAME	VALUE	FUNCTION
SR.7	BS	Bus Status; note 1	1	bus-off; the CAN controller is not involved in bus activities
			0	bus-on; the CAN controller is involved in bus activities
SR.6	ES	Error Status; note 2	1	error; at least one of the error counters has reached or exceeded the CPU warning limit defined by the Error Warning Limit Register (EWLR)
			0	ok; both error counters are below the warning limit
SR.5	TS	Transmit Status; note 3	1	transmit; the CAN controller is transmitting a message
			0	idle
SR.4	RS	Receive Status; note 3	1	receive; the CAN controller is receiving a message
			0	idle
SR.3	TCS	Transmission Complete Status; note 4	1	complete; last requested transmission has been successfully completed
			0	incomplete; previously requested transmission is not yet completed
SR.2	TBS	Transmit Buffer Status; note 5	1	released; the CPU may write a message into the transmit buffer
			0	locked; the CPU cannot access the transmit buffer; a message is either waiting for transmission or is in the process of being transmitted

Stand-alone CAN controller

SJA1000

BIT	SYMBOL	NAME	VALUE	FUNCTION
SR.1	DOS	Data Overrun Status; note 6	1	overrun; a message was lost because there was not enough space for that message in the RXFIFO
			0	absent; no data overrun has occurred since the last clear data overrun command was given
SR.0	RBS	Receive Buffer Status; note 7	1	full; one or more complete messages are available in the RXFIFO
			0	empty; no message is available

Notes

- When the transmit error counter exceeds the limit of 255, the bus status bit is set to logic 1 (bus-off), the CAN controller will set the reset mode bit to logic 1 (present) and an error warning interrupt is generated, if enabled. The transmit error counter is set to 127 and the receive error counter is cleared. It will stay in this mode until the CPU clears the reset mode bit. Once this is completed the CAN controller will wait the minimum protocol-defined time (128 occurrences of the bus-free signal) counting down the transmit error counter. After that the bus status bit is cleared (bus-on), the error status bit is set to logic 0 (ok), the error counters are reset and an error warning interrupt is generated, if enabled. Reading the TX error counter during this time gives information about the status of the bus-off recovery.
- Errors detected during reception or transmission will effect the error counters according to the CAN 2.0B protocol specification. The error status bit is set when at least one of the error counters has reached or exceeded the CPU warning limit (EWLR). An error warning interrupt is generated, if enabled. The default value of EWLR after hardware reset is 96.
- If both the receive status and the transmit status bits are logic 0 (idle) the CAN-bus is idle. If both bits are set the controller is waiting to become idle again. After a hardware reset 11 consecutive recessive bits have to be detected until the idle status is reached. After bus-off this will take 128 of 11 consecutive recessive bits.
- The transmission complete status bit is set to logic 0 (incomplete) whenever the transmission request bit or the self reception request bit is set to logic 1. The transmission complete status bit will remain at logic 0 until a message is transmitted successfully.
- If the CPU tries to write to the transmit buffer when the transmit buffer status bit is logic 0 (locked), the written byte will not be accepted and will be lost without this being indicated.
- When a message that is to be received has passed the acceptance filter successfully, the CAN controller needs space in the RXFIFO to store the message descriptor and for each data byte which has been received. If there is not enough space to store the message, that message is dropped and the data overrun condition is indicated to the CPU at the moment this message becomes valid. If this message is not completed successfully (e.g. due to an error), no overrun condition is indicated.
- After reading all messages within the RXFIFO and releasing their memory space with the command release receive buffer this bit is cleared.

Stand-alone CAN controller

SJA1000

6.4.6 INTERRUPT REGISTER (IR)

The interrupt register allows the identification of an interrupt source. When one or more bits of this register are set, a CAN interrupt will be indicated to the CPU. After this register is read by the CPU all bits are reset except for the receive interrupt bit.

The interrupt register appears to the CPU as a read only memory.

Table 15 Bit interpretation of the interrupt register (IR); CAN address 3

BIT	SYMBOL	NAME	VALUE	FUNCTION
IR.7	BEI	Bus Error Interrupt	1	set; this bit is set when the CAN controller detects an error on the CAN-bus and the BEIE bit is set within the interrupt enable register
			0	reset
IR.6	ALI	Arbitration Lost Interrupt	1	set; this bit is set when the CAN controller lost the arbitration and becomes a receiver and the ALIE bit is set within the interrupt enable register
			0	reset
IR.5	EPI	Error Passive Interrupt	1	set; this bit is set whenever the CAN controller has reached the error passive status (at least one error counter exceeds the protocol-defined level of 127) or if the CAN controller is in the error passive status and enters the error active status again and the EPIE bit is set within the interrupt enable register
			0	reset
IR.4	WUI	Wake-Up Interrupt; note 1	1	set; this bit is set when the CAN controller is sleeping and bus activity is detected and the WUIE bit is set within the interrupt enable register
			0	reset
IR.3	DOI	Data Overrun Interrupt	1	set; this bit is set on a '0-to-1' transition of the data overrun status bit and the DOIE bit is set within the interrupt enable register
			0	reset
IR.2	EI	Error Warning Interrupt	1	set; this bit is set on every change (set and clear) of either the error status or bus status bits and the EIE bit is set within the interrupt enable register
			0	reset
IR.1	TI	Transmit Interrupt	1	set; this bit is set whenever the transmit buffer status changes from '0-to-1' (released) and the TIE bit is set within the interrupt enable register
			0	reset
IR.0	RI	Receive Interrupt; note 2	1	set; this bit is set while the receive FIFO is not empty and the RIE bit is set within the interrupt enable register
			0	reset; no more message is available within the RXFIFO

Stand-alone CAN controller

SJA1000

Notes

1. A wake-up interrupt is also generated, if the CPU tries to set the sleep bit while the CAN controller is involved in bus activities or a CAN interrupt is pending.
2. The behaviour of this bit is equivalent to that of the receive buffer status bit with the exception, that RI depends on the corresponding interrupt enable bit (RIE). So the receive interrupt bit is not cleared upon a read access to the interrupt register. Giving the command 'release receive buffer' will clear RI temporarily. If there is another message available within the FIFO after the release command, RI is set again. Otherwise RI remains cleared.

6.4.7 INTERRUPT ENABLE REGISTER (IER)

The register allows to enable different types of interrupt sources which are indicated to the CPU.

The interrupt enable register appears to the CPU as a read/write memory.

Table 16 Bit interpretation of the interrupt enable register (IER); CAN address 4

BIT	SYMBOL	NAME	VALUE	FUNCTION
IER.7	BEIE	Bus Error Interrupt Enable	1	enabled; if an bus error has been detected, the CAN controller requests the respective interrupt
			0	disabled
IER.6	ALIE	Arbitration Lost Interrupt Enable	1	enabled; if the CAN controller has lost arbitration, the respective interrupt is requested
			0	disabled
IER.5	EPIE	Error Passive Interrupt Enable	1	enabled; if the error status of the CAN controller changes from error active to error passive or vice versa, the respective interrupt is requested
			0	disabled
IER.4	WUIE	Wake-Up Interrupt Enable	1	enabled; if the sleeping CAN controller wakes up, the respective interrupt is requested
			0	disabled
IER.3	DOIE	Data Overrun Interrupt Enable	1	enabled; if the data overrun status bit is set (see status register; Table 14), the CAN controller requests the respective interrupt
			0	disabled
IER.2	EIE	Error Warning Interrupt Enable	1	enabled; if the error or bus status change (see status register; Table 14), the CAN controller requests the respective interrupt
			0	disabled
IER.1	TIE	Transmit Interrupt Enable	1	enabled; when a message has been successfully transmitted or the transmit buffer is accessible again (e.g. after an abort transmission command), the CAN controller requests the respective interrupt
			0	disabled
IER.0	RIE	Receive Interrupt Enable; note 1	1	enabled; when the receive buffer status is 'full' the CAN controller requests the respective interrupt
			0	disabled

Stand-alone CAN controller

SJA1000

Note

1. The receive interrupt enable bit has direct influence to the receive interrupt bit and the external interrupt output \overline{INT} . If RIE is cleared, the external \overline{INT} pin will become HIGH immediately, if there is no other interrupt pending.

6.4.8 ARBITRATION LOST CAPTURE REGISTER (ALC)

This register contains information about the bit position of losing arbitration. The arbitration lost capture register appears to the CPU as a read only memory. Reserved bits are read as logic 0.

Table 17 Bit interpretation of the arbitration lost capture register (ALC); CAN address 11

BIT	SYMBOL	NAME	VALUE	FUNCTION
ALC.7 to ALC.5	–	reserved	For value and function see Table 18	
ALC.4	BITNO4	bit number 4		
ALC.3	BITNO3	bit number 3		
ALC.2	BITNO2	bit number 2		
ALC.1	BITNO1	bit number 1		
ALC.0	BITNO0	bit number 0		

On arbitration lost, the corresponding arbitration lost interrupt is forced, if enabled. At the same time, the current bit position of the bit stream processor is captured into the arbitration lost capture register. The content within this register is fixed until the users software has read out its contents once. The capture mechanism is then activated again.

The corresponding interrupt flag located in the interrupt register is cleared during the read access to the interrupt register. A new arbitration lost interrupt is not possible until the arbitration lost capture register is read out once.

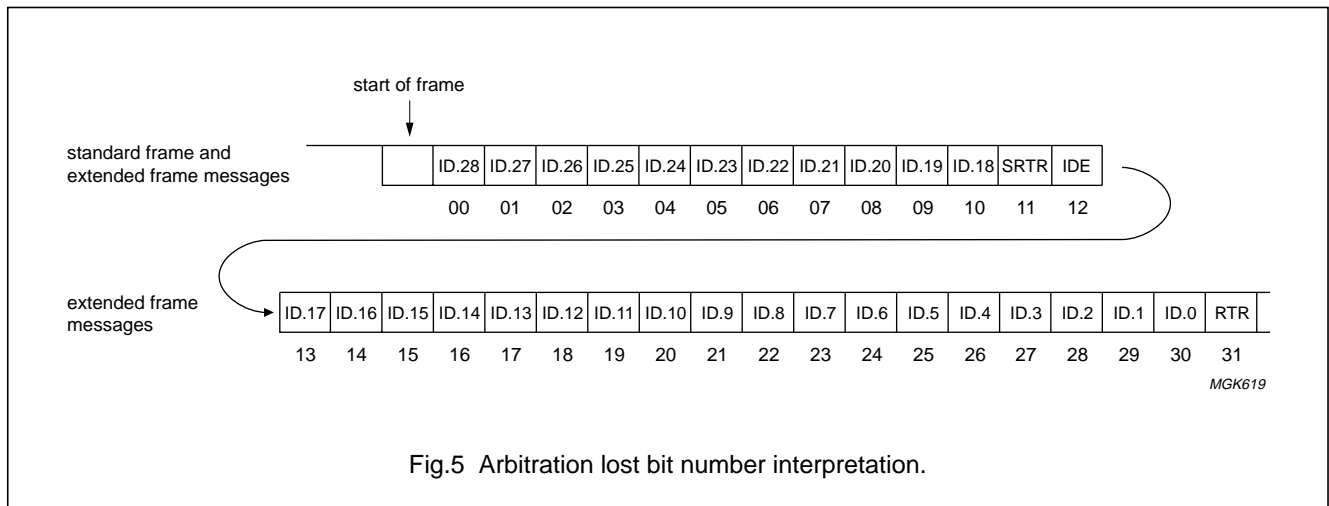

Stand-alone CAN controller

SJA1000

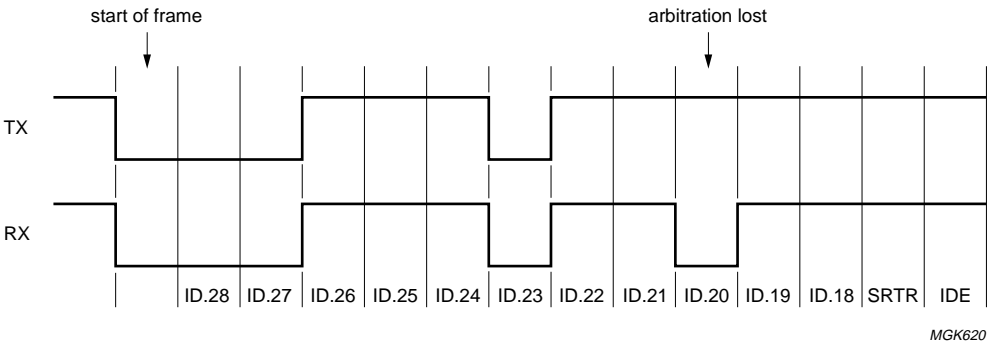

Fig.6 Example of arbitration lost bit number interpretation; result: ALC = 08.

Stand-alone CAN controller

SJA1000

Table 18 Function of bits 4 to 0 of the arbitration lost capture register

BITS ⁽¹⁾					DECIMAL VALUE	FUNCTION
ALC.4	ALC.3	ALC.2	ALC.1	ALC.0		
0	0	0	0	0	00	arbitration lost in bit 1 of identifier
0	0	0	0	1	01	arbitration lost in bit 2 of identifier
0	0	0	1	0	02	arbitration lost in bit 3 of identifier
0	0	0	1	1	03	arbitration lost in bit 4 of identifier
0	0	1	0	0	04	arbitration lost in bit 5 of identifier
0	0	1	0	1	05	arbitration lost in bit 6 of identifier
0	0	1	1	0	06	arbitration lost in bit 7 of identifier
0	0	1	1	1	07	arbitration lost in bit 8 of identifier
0	1	0	0	0	08	arbitration lost in bit 9 of identifier
0	1	0	0	1	09	arbitration lost in bit 10 of identifier
0	1	0	1	0	10	arbitration lost in bit 11 of identifier
0	1	0	1	1	11	arbitration lost in bit SRTR; note 2
0	1	1	0	0	12	arbitration lost in bit IDE
0	1	1	0	1	13	arbitration lost in bit 12 of identifier; note 3
0	1	1	1	0	14	arbitration lost in bit 13 of identifier; note 3
0	1	1	1	1	15	arbitration lost in bit 14 of identifier; note 3
1	0	0	0	0	16	arbitration lost in bit 15 of identifier; note 3
1	0	0	0	1	17	arbitration lost in bit 16 of identifier; note 3
1	0	0	1	0	18	arbitration lost in bit 17 of identifier; note 3
1	0	0	1	1	19	arbitration lost in bit 18 of identifier; note 3
1	0	1	0	0	20	arbitration lost in bit 19 of identifier; note 3
1	0	1	0	1	21	arbitration lost in bit 20 of identifier; note 3
1	0	1	1	0	22	arbitration lost in bit 21 of identifier; note 3
1	0	1	1	1	23	arbitration lost in bit 22 of identifier; note 3
1	1	0	0	0	24	arbitration lost in bit 23 of identifier; note 3
1	1	0	0	1	25	arbitration lost in bit 24 of identifier; note 3
1	1	0	1	0	26	arbitration lost in bit 25 of identifier; note 3
1	1	0	1	1	27	arbitration lost in bit 26 of identifier; note 3
1	1	1	0	0	28	arbitration lost in bit 27 of identifier; note 3
1	1	1	0	1	29	arbitration lost in bit 28 of identifier; note 3
1	1	1	1	0	30	arbitration lost in bit 29 of identifier; note 3
1	1	1	1	1	31	arbitration lost in bit RTR; note 3

Notes

1. Binary coded frame bit number where arbitration was lost.
2. Bit RTR for standard frame messages.
3. Extended frame messages only.

Stand-alone CAN controller

SJA1000

6.4.9 ERROR CODE CAPTURE REGISTER (ECC)

This register contains information about the type and location of errors on the bus. The error code capture register appears to the CPU as a read only memory.

Table 19 Bit interpretation of the error code capture register (ECC); CAN address 12

BIT	SYMBOL	NAME	VALUE	FUNCTION
ECC.7 ⁽¹⁾	ERRC1	Error Code 1	–	–
ECC.6 ⁽¹⁾	ERRC0	Error Code 0	–	–
ECC.5	DIR	Direction	1	RX; error occurred during reception
			0	TX; error occurred during transmission
ECC.4 ⁽²⁾	SEG4	Segment 4	–	–
ECC.3 ⁽²⁾	SEG3	Segment 3	–	–
ECC.2 ⁽²⁾	SEG2	Segment 2	–	–
ECC.1 ⁽²⁾	SEG1	Segment 1	–	–
ECC.0 ⁽²⁾	SEG0	Segment 0	–	–

Notes

1. For bit interpretation of bits ECC.7 and ECC.6 see Table 20.
2. For bit interpretation of bits ECC.4 to ECC.0 see Table 21.

Table 20 Bit interpretation of bits ECC.7 and ECC.6

BIT ECC.7	BIT ECC.6	FUNCTION
0	0	bit error
0	1	form error
1	0	stuff error
1	1	other type of error

Stand-alone CAN controller

SJA1000

Table 21 Bit interpretation of bits ECC.4 to ECC.0; note 1

BIT ECC.4	BIT ECC.3	BIT ECC.2	BIT ECC.1	BIT ECC.0	FUNCTION
0	0	0	1	1	start of frame
0	0	0	1	0	ID.28 to ID.21
0	0	1	1	0	ID.20 to ID.18
0	0	1	0	0	bit SRTR
0	0	1	0	1	bit IDE
0	0	1	1	1	ID.17 to ID.13
0	1	1	1	1	ID.12 to ID.5
0	1	1	1	0	ID.4 to ID.0
0	1	1	0	0	bit RTR
0	1	1	0	1	reserved bit 1
0	1	0	0	1	reserved bit 0
0	1	0	1	1	data length code
0	1	0	1	0	data field
0	1	0	0	0	CRC sequence
1	1	0	0	0	CRC delimiter
1	1	0	0	1	acknowledge slot
1	1	0	1	1	acknowledge delimiter
1	1	0	1	0	end of frame
1	0	0	1	0	intermission
1	0	0	0	1	active error flag
1	0	1	1	0	passive error flag
1	0	0	1	1	tolerate dominant bits
1	0	1	1	1	error delimiter
1	1	1	0	0	overload flag

Note

1. Bit settings reflect the current frame segment to distinguish between different error events.

If a bus error occurs, the corresponding bus error interrupt is always forced, if enabled. At the same time, the current position of the bit stream processor is captured into the error code capture register. The content within this register is fixed until the users software has read out its content once. The capture mechanism is then activated again.

The corresponding interrupt flag located in the interrupt register is cleared during the read access to the interrupt register. A new bus error interrupt is not possible until the capture register is read out once.

6.4.10 ERROR WARNING LIMIT REGISTER (EWLR)

The error warning limit can be defined within this register. The default value (after hardware reset) is 96. In reset mode this register appears to the CPU as a read/write memory. In operating mode it is read only.

Note, that a content change of the EWLR is only possible, if the reset mode was entered previously. An error status change (see status register; Table 14) and an error warning interrupt forced by the new register content will not occur until the reset mode is cancelled again.

Stand-alone CAN controller

SJA1000

Table 22 Bit interpretation of the error warning limit register (EWLR); CAN address 13

BIT 7	BIT 6	BIT 5	BIT 4	BIT 3	BIT 2	BIT 1	BIT 0
EWL.7	EWL.6	EWL.5	EWL.4	EWL.3	EWL.2	EWL.1	EWL.0

6.4.11 RX ERROR COUNTER REGISTER (RXERR)

The RX error counter register reflects the current value of the receive error counter. After a hardware reset this register is initialized to logic 0. In operating mode this register appears to the CPU as a read only memory. A write access to this register is possible only in reset mode.

If a bus-off event occurs, the RX error counter is initialized to logic 0. The time bus-off is valid, writing to this register has no effect.

Note, that a CPU-forced content change of the RX error counter is only possible, if the reset mode was entered previously. An error status change (see status register; Table 14), an error warning or an error passive interrupt forced by the new register content will not occur, until the reset mode is cancelled again.

Table 23 Bit interpretation of the RX error counter register (RXERR); CAN address 14

BIT 7	BIT 6	BIT 5	BIT 4	BIT 3	BIT 2	BIT 1	BIT 0
RXERR.7	RXERR.6	RXERR.5	RXERR.4	RXERR.3	RXERR.2	RXERR.1	RXERR.0

6.4.12 TX ERROR COUNTER REGISTER (TXERR)

The TX error counter register reflects the current value of the transmit error counter.

In operating mode this register appears to the CPU as a read only memory. A write access to this register is possible only in reset mode. After a hardware reset this register is initialized to logic 0. If a bus-off event occurs, the TX error counter is initialized to 127 to count the minimum protocol-defined time (128 occurrences of the bus-free signal). Reading the TX error counter during this time gives information about the status of the bus-off recovery.

If bus-off is active, a write access to TXERR in the range from 0 to 254 clears the bus-off flag and the controller will wait for one occurrence of 11 consecutive recessive bits (bus-free) after the reset mode has been cleared.

Table 24 Bit interpretation of the TX error counter register (TXERR); CAN address 15

BIT 7	BIT 6	BIT 5	BIT 4	BIT 3	BIT 2	BIT 1	BIT 0
TXERR.7	TXERR.6	TXERR.5	TXERR.4	TXERR.3	TXERR.2	TXERR.1	TXERR.0

Writing 255 to TXERR allows to initiate a CPU-driven bus-off event. It should be noted that a CPU-forced content change of the TX error counter is only possible, if the reset mode was entered previously. An error or bus status change (see status register; Table 14), an error warning or an error passive interrupt forced by the new register content will not occur until the reset mode is cancelled again. After leaving the reset mode, the new TX counter content is interpreted and the bus-off event is performed in the same way, as if it was forced by a bus error event. That means, that the reset mode is entered again, the TX error counter is initialized to 127, the RX counter is cleared and all concerned status and interrupt register bits are set.

Clearing of reset mode now will perform the protocol-defined bus-off recovery sequence (waiting for 128 occurrences of the bus-free signal).

If the reset mode is entered again before the end of bus-off recovery (TXERR > 0), bus-off keeps active and TXERR is frozen.

Stand-alone CAN controller

SJA1000

6.4.13 TRANSMIT BUFFER

The global layout of the transmit buffer is shown in Fig.7. One has to distinguish between the Standard Frame Format (SFF) and the Extended Frame Format (EFF) configuration. The transmit buffer allows the definition of one transmit message with up to eight data bytes.

The transmit buffer has a length of 13 bytes and is located in the CAN address range from 16 to 28.

Note, that a direct access to the transmit buffer RAM is possible using the CAN address space from 96 to 108. This RAM area is reserved for the transmit buffer. The three following bytes may be used for general purposes (CAN address 109, 110 and 111).

6.4.13.1 Transmit buffer layout

The transmit buffer layout is subdivided into descriptor and data fields where the first byte of the descriptor field is the frame information byte (frame information). It describes the frame format (SFF or EFF), remote or data frame and the data length. Two identifier bytes for SFF or four bytes for EFF messages follow. The data field contains up to eight data bytes.

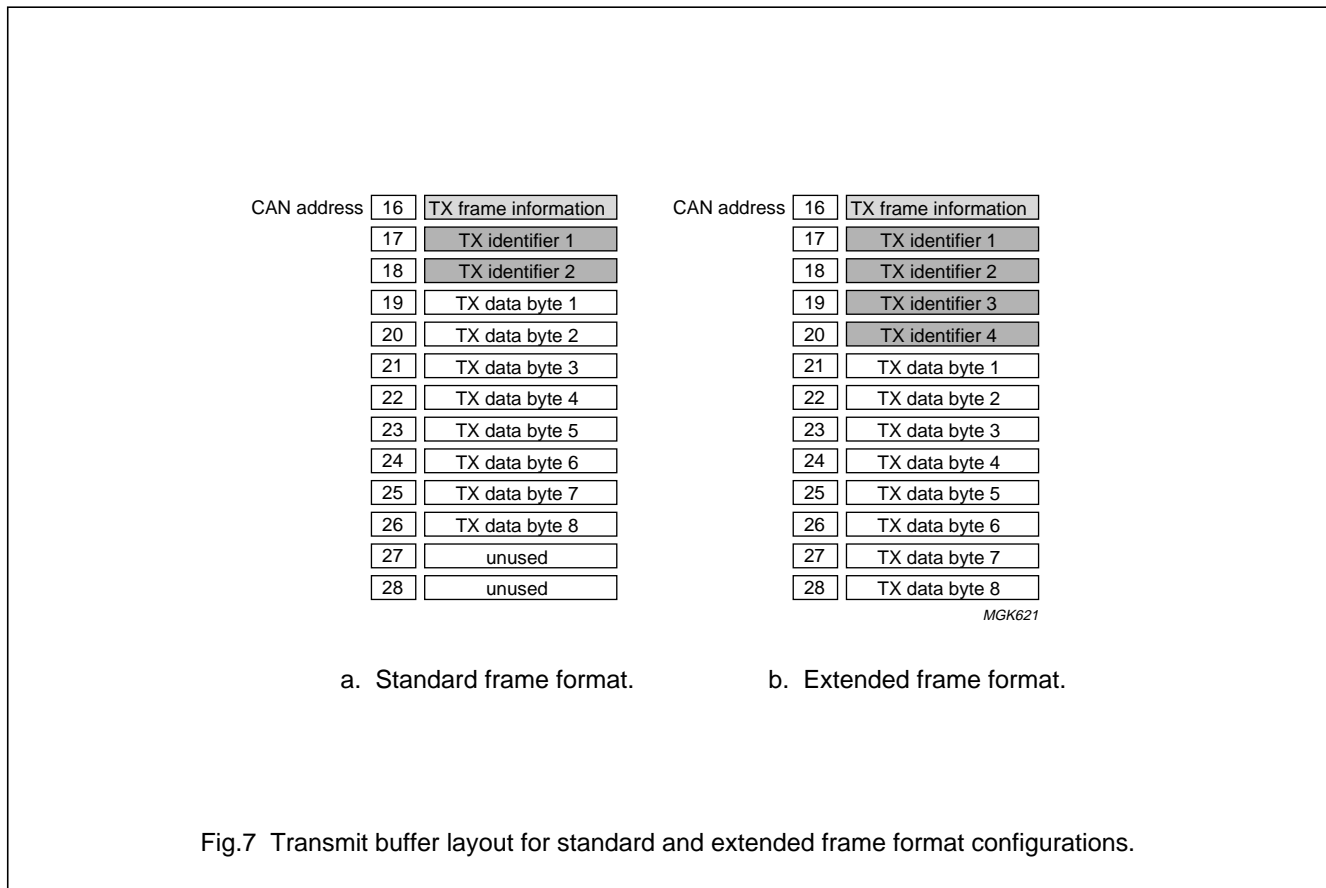

6.4.13.2 Descriptor field of the transmit buffer

The bit layout of the transmit buffer is represented in Tables 25 to 27 for SFF and Tables 28 to 32 for EFF. The given configuration is chosen to be compatible with the receive buffer layout (see Section 6.4.14.1).

Stand-alone CAN controller

SJA1000

Table 25 TX frame information (SFF); CAN address 16

BIT 7	BIT 6	BIT 5	BIT 4	BIT 3	BIT 2	BIT 1	BIT 0
FF ⁽¹⁾	RTR ⁽²⁾	X ⁽³⁾	X ⁽³⁾	DLC.3 ⁽⁴⁾	DLC.2 ⁽⁴⁾	DLC.1 ⁽⁴⁾	DLC.0 ⁽⁴⁾

Notes

1. Frame format.
2. Remote transmission request.
3. Don't care; recommended to be compatible to receive buffer (0) in case of using the self reception facility (self test).
4. Data length code bit.

Table 26 TX identifier 1 (SFF); CAN address 17; note 1

BIT 7	BIT 6	BIT 5	BIT 4	BIT 3	BIT 2	BIT 1	BIT 0
ID.28	ID.27	ID.26	ID.25	ID.24	ID.23	ID.22	ID.21

Note

1. ID.X means identifier bit X.

Table 27 TX identifier 2 (SFF); CAN address 18; note 1

BIT 7	BIT 6	BIT 5	BIT 4	BIT 3	BIT 2	BIT 1	BIT 0
ID.20	ID.19	ID.18	X ⁽²⁾	X ⁽³⁾	X ⁽³⁾	X ⁽³⁾	X ⁽³⁾

Notes

1. ID.X means identifier bit X.
2. Don't care; recommended to be compatible to receive buffer (RTR) in case of using the self reception facility (self test).
3. Don't care; recommended to be compatible to receive buffer (0) in case of using the self reception facility (self test).

Table 28 TX frame information (EFF); CAN address 16

BIT 7	BIT 6	BIT 5	BIT 4	BIT 3	BIT 2	BIT 1	BIT 0
FF ⁽¹⁾	RTR ⁽²⁾	X ⁽³⁾	X ⁽³⁾	DLC.3 ⁽⁴⁾	DLC.2 ⁽⁴⁾	DLC.1 ⁽⁴⁾	DLC.0 ⁽⁴⁾

Notes

1. Frame format.
2. Remote transmission request.
3. Don't care; recommended to be compatible to receive buffer (0) in case of using the self reception facility (self test).
4. Data length code bit.

Table 29 TX identifier 1 (EFF); CAN address 17; note 1

BIT 7	BIT 6	BIT 5	BIT 4	BIT 3	BIT 2	BIT 1	BIT 0
ID.28	ID.27	ID.26	ID.25	ID.24	ID.23	ID.22	ID.21

Note

1. ID.X means identifier bit X.

Stand-alone CAN controller

SJA1000

Table 30 TX identifier 2 (EFF); CAN address 18; note 1

BIT 7	BIT 6	BIT 5	BIT 4	BIT 3	BIT 2	BIT 1	BIT 0
ID.20	ID.19	ID.18	ID.17	ID.16	ID.15	ID.14	ID.13

Note

1. ID.X means identifier bit X.

Table 31 TX identifier 3 (EFF); CAN address 19; note 1

BIT 7	BIT 6	BIT 5	BIT 4	BIT 3	BIT 2	BIT 1	BIT 0
ID.12	ID.11	ID.10	ID.9	ID.8	ID.7	ID.6	ID.5

Note

1. ID.X means identifier bit X.

Table 32 TX identifier 4 (EFF); CAN address 20; note 1

BIT 7	BIT 6	BIT 5	BIT 4	BIT 3	BIT 2	BIT 1	BIT 0
ID.4	ID.3	ID.2	ID.1	ID.0	X ⁽²⁾	X ⁽³⁾	X ⁽³⁾

Notes

1. ID.X means identifier bit X.
2. Don't care; recommended to be compatible to receive buffer (RTR) in case of using the self reception facility (self test).
3. Don't care; recommended to be compatible to receive buffer (0) in case of using the self reception facility (self test).

Table 33 Frame Format (FF) and Remote Transmission Request (RTR) bits

BIT	VALUE	FUNCTION
FF	1	EFF; extended frame format will be transmitted by the CAN controller
	0	SFF; standard frame format will be transmitted by the CAN controller
RTR	1	remote; remote frame will be transmitted by the CAN controller
	0	data; data frame will be transmitted by the CAN controller

6.4.13.3 Data Length Code (DLC)

The number of bytes in the data field of a message is coded by the data length code. At the start of a remote frame transmission the data length code is not considered due to the RTR bit being logic 1 (remote). This forces the number of transmitted/received data bytes to be 0. Nevertheless, the data length code must be specified correctly to avoid bus errors, if two CAN controllers start a remote frame transmission with the same identifier simultaneously.

The range of the data byte count is 0 to 8 bytes and is coded as follows:

$$\text{DataByteCount} = 8 \times \text{DLC.3} + 4 \times \text{DLC.2} + 2 \times \text{DLC.1} + \text{DLC.0}$$

For reasons of compatibility no data length code >8 should be used. If a value >8 is selected, 8 bytes are transmitted in the data frame with the Data Length Code specified in DLC.

6.4.13.4 Identifier (ID)

In Standard Frame Format (SFF) the identifier consists of 11 bits (ID.28 to ID.18) and in Extended Frame Format (EFF) messages the identifier consists of 29 bits (ID.28 to ID.0). ID.28 is the most significant bit, which is transmitted first on the bus during the arbitration process. The identifier acts as the message's name, used in a receiver for acceptance filtering, and also determines the bus access priority during the arbitration process.

Stand-alone CAN controller

SJA1000

The lower the binary value of the identifier the higher the priority. This is due to the larger number of leading dominant bits during arbitration.

6.4.13.5 Data field

The number of transferred data bytes is defined by the data length code. The first bit transmitted is the most significant bit of data byte 1 at CAN address 19 (SFF) or CAN address 21 (EFF).

6.4.14 RECEIVE BUFFER

The global layout of the receive buffer is very similar to the transmit buffer described in the previous section. The receive buffer is the accessible part of the RXFIFO and is located in the range between CAN address 16 and 28. Each message is subdivided into a descriptor and a data field.

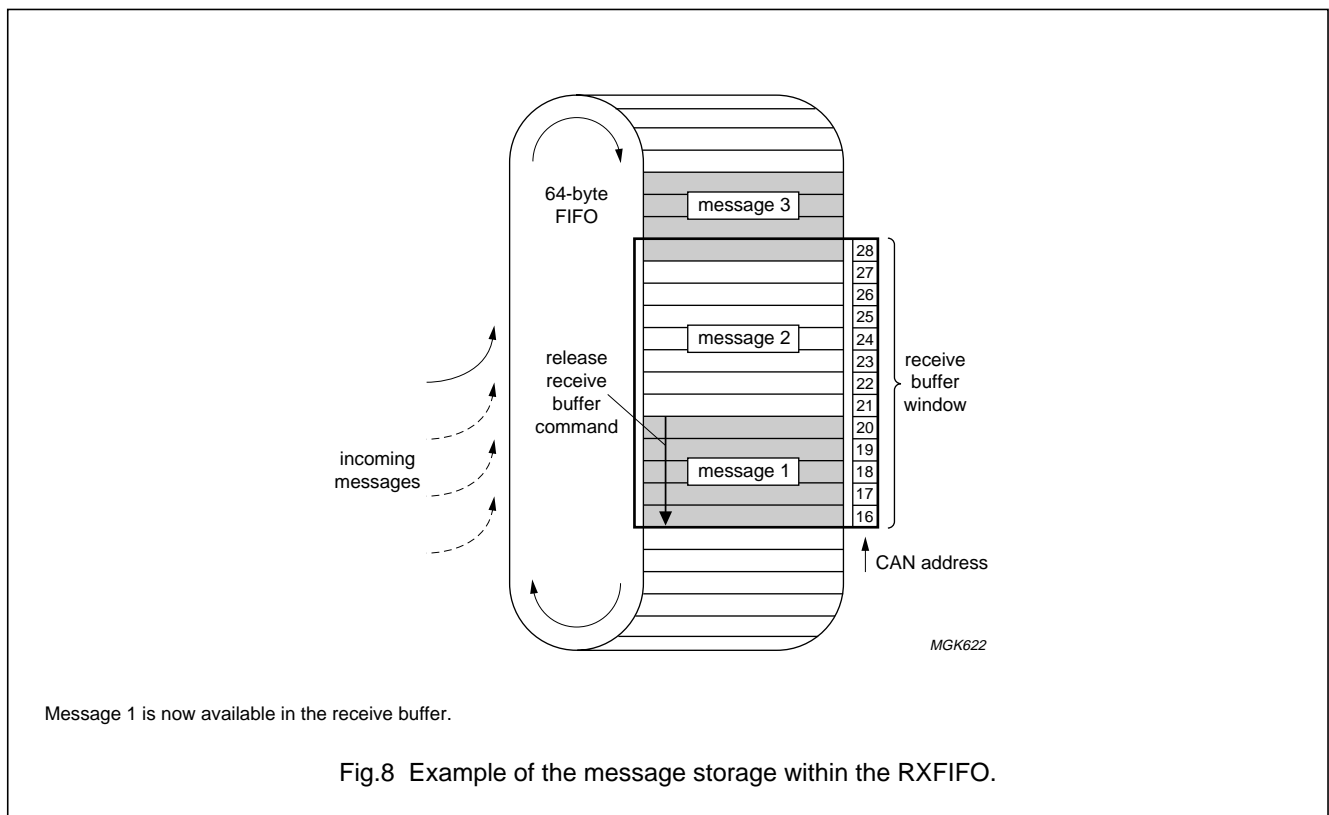

6.4.14.1 Descriptor field of the receive buffer

The bit layout of the receive buffer is represented in Tables 34 to 36 for SFF and Tables 37 to 41 for EFF. The given configuration is chosen to be compatible with the transmit buffer layout (see Section 6.4.13.2).

Table 34 RX frame information (SFF); CAN address 16

BIT 7	BIT 6	BIT 5	BIT 4	BIT 3	BIT 2	BIT 1	BIT 0
FF ⁽¹⁾	RTR ⁽²⁾	0	0	DLC.3 ⁽³⁾	DLC.2 ⁽³⁾	DLC.1 ⁽³⁾	DLC.0 ⁽³⁾

Notes

1. Frame format.
2. Remote transmission request.
3. Data length code bit.

Stand-alone CAN controller

SJA1000

Table 35 RX identifier 1 (SFF); CAN address 17; note 1

BIT 7	BIT 6	BIT 5	BIT 4	BIT 3	BIT 2	BIT 1	BIT 0
ID.28	ID.27	ID.26	ID.25	ID.24	ID.23	ID.22	ID.21

Note

1. ID.X means identifier bit X.

Table 36 RX identifier 2 (SFF); CAN address 18; note 1

BIT 7	BIT 6	BIT 5	BIT 4	BIT 3	BIT 2	BIT 1	BIT 0
ID.20	ID.19	ID.18	RTR ⁽²⁾	0	0	0	0

Notes

1. ID.X means identifier bit X.
2. Remote transmission request.

Table 37 RX frame information (EFF); CAN address 16

BIT 7	BIT 6	BIT 5	BIT 4	BIT 3	BIT 2	BIT 1	BIT 0
FF ⁽¹⁾	RTR ⁽²⁾	0	0	DLC.3 ⁽³⁾	DLC.2 ⁽³⁾	DLC.1 ⁽³⁾	DLC.0 ⁽³⁾

Notes

1. Frame format.
2. Remote transmission request.
3. Data length code bit.

Table 38 RX identifier 1 (EFF); CAN address 17; note 1

BIT 7	BIT 6	BIT 5	BIT 4	BIT 3	BIT 2	BIT 1	BIT 0
ID.28	ID.27	ID.26	ID.25	ID.24	ID.23	ID.22	ID.21

Note

1. ID.X means identifier bit X.

Table 39 RX identifier 2 (EFF); CAN address 18; note 1

BIT 7	BIT 6	BIT 5	BIT 4	BIT 3	BIT 2	BIT 1	BIT 0
ID.20	ID.19	ID.18	ID.17	ID.16	ID.15	ID.14	ID.13

Note

1. ID.X means identifier bit X.

Table 40 RX identifier 3 (EFF); CAN address 19; note 1

BIT 7	BIT 6	BIT 5	BIT 4	BIT 3	BIT 2	BIT 1	BIT 0
ID.12	ID.11	ID.10	ID.9	ID.8	ID.7	ID.6	ID.5

Note

1. ID.X means identifier bit X.

Stand-alone CAN controller

SJA1000

Table 41 RX identifier 4 (EFF); can address 20; note 1

BIT 7	BIT 6	BIT 5	BIT 4	BIT 3	BIT 2	BIT 1	BIT 0
ID.4	ID.3	ID.2	ID.1	ID.0	RTR ⁽²⁾	0	0

Notes

1. ID.X means identifier bit X.
2. Remote transmission request.

Remark: the received data length code located in the frame information byte represents the real sent data length code, which may be greater than 8 (depends on sender). Nevertheless the maximum number of received data bytes is 8. This should be taken into account by reading a message from the receive buffer.

As described in Fig.8 the RXFIFO has space for 64 message bytes in total. It depends on the data length how many messages can fit in it at one time. If there is not enough space for a new message within the RXFIFO, the CAN controller generates a data overrun condition the moment this message becomes valid and the acceptance test was positive. A message which is partly written into the RXFIFO, when the data overrun situation occurs, is deleted. This situation is indicated to the CPU via the status register and the data overrun interrupt, if enabled.

6.4.15 ACCEPTANCE FILTER

With the help of the acceptance filter the CAN controller is able to allow passing of received messages to the RXFIFO only when the identifier bits of the received message are equal to the predefined ones within the acceptance filter registers.

The acceptance filter is defined by the Acceptance Code Registers (ACRn) and the Acceptance Mask Registers (AMRn). The bit patterns of messages to be received are defined within the acceptance code registers.

The corresponding acceptance mask registers allow to define certain bit positions to be 'don't care'.

Two different filter modes are selectable within the mode register (MOD.3, AFM; see Section 6.4.3):

- Single filter mode (bit AFM is logic 1)
- Dual filter mode (bit AFM is logic 0).

6.4.15.1 Single filter configuration

In this filter configuration one long filter (4-bytes) could be defined. The bit correspondences between the filter bytes and the message bytes depend on the currently received frame format.

Standard frame: if a standard frame format message is received, the complete identifier including the RTR bit and the first two data bytes are used for acceptance filtering. Messages may also be accepted if there are no data bytes existing due to a set RTR bit or if there is none or only one data byte because of the corresponding data length code.

For a successful reception of a message, all single bit comparisons have to signal acceptance.

Note, that the 4 least significant bits of AMR1 and ACR1 are not used. In order to be compatible with future products these bits should be programmed to be 'don't care' by setting AMR1.3, AMR1.2, AMR1.1 and AMR1.0 to logic 1.

Stand-alone CAN controller

SJA1000

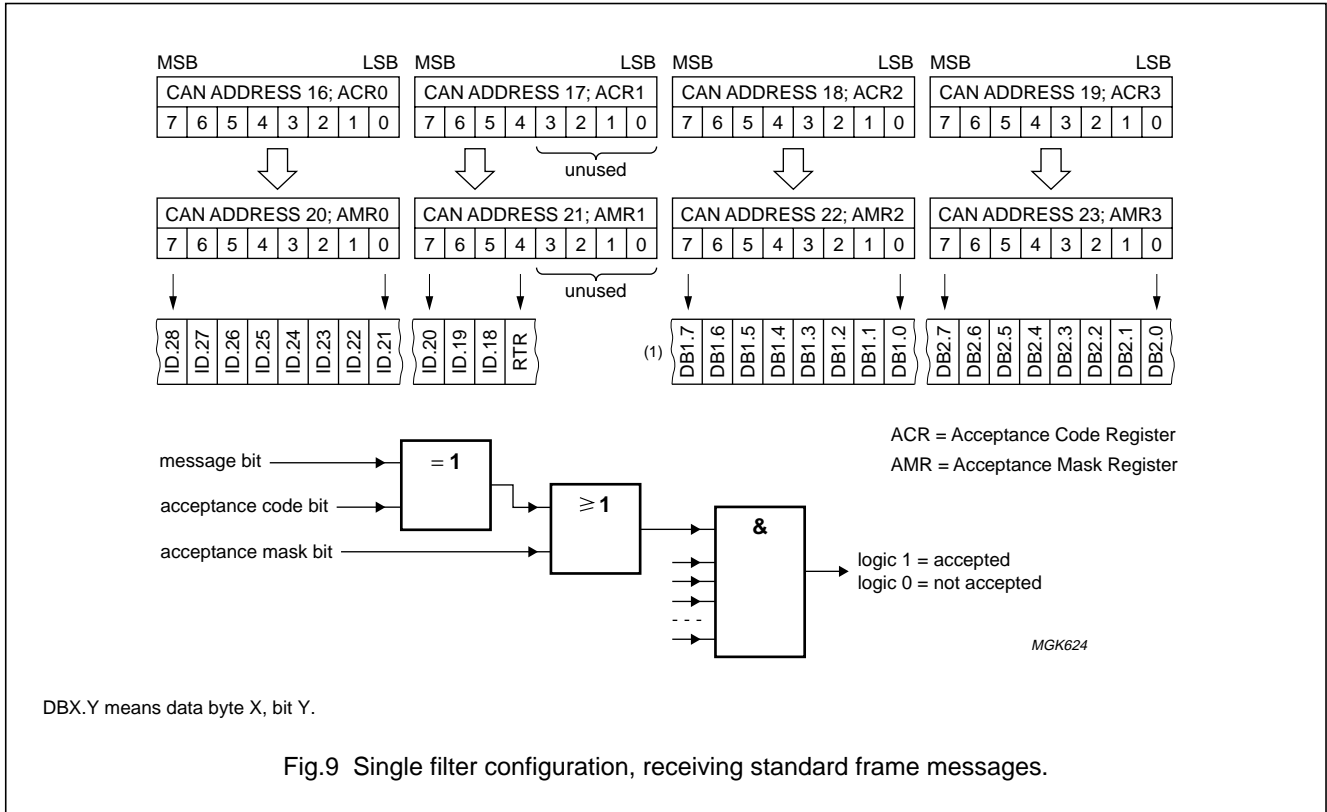

Fig.9 Single filter configuration, receiving standard frame messages.

Extended frame: if an extended frame format message is received, the complete identifier including the RTR bit is used for acceptance filtering.

For a successful reception of a message, all single bit comparisons have to signal acceptance.

It should be noted that the 2 least significant bits of AMR3 and ACR3 are not used. In order to be compatible with future products these bits should be programmed to be 'don't care' by setting AMR3.1 and AMR3.0 to logic 1.

Stand-alone CAN controller

SJA1000

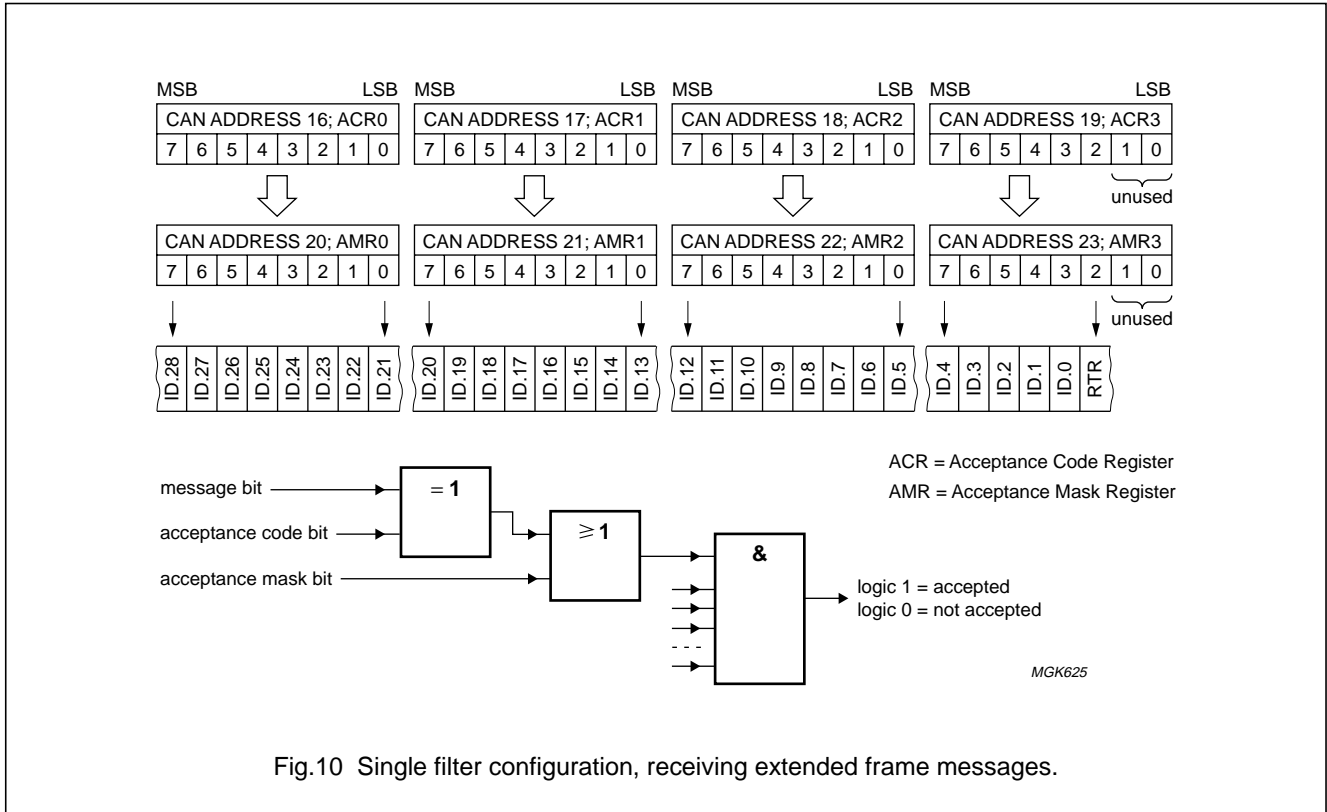

Fig.10 Single filter configuration, receiving extended frame messages.

6.4.15.2 Dual filter configuration

In this filter configuration two short filters can be defined. A received message is compared with both filters to decide, whether this message should be copied into the receive buffer or not. If at least one of the filters signals an acceptance, the received message becomes valid. The bit correspondences between the filter bytes and the message bytes depends on the currently received frame format.

Standard frame: if a standard frame message is received, the two defined filters are looking different. The first filter compares the complete standard identifier including the RTR bit and the first data byte of the message. The second filter just compares the complete standard identifier including the RTR bit.

For a successful reception of a message, all single bit comparisons of at least one complete filter have to signal acceptance. In case of a set RTR bit or a data length code of logic 0 no data byte is existing. Nevertheless a message may pass filter 1, if the first part up to the RTR bit signals acceptance.

If no data byte filtering is required for filter 1, the four least significant bits of AMR1 and AMR3 have to be set to logic 1 (don't care). Then both filters are working identically using the standard identifier range including the RTR bit.

Stand-alone CAN controller

SJA1000

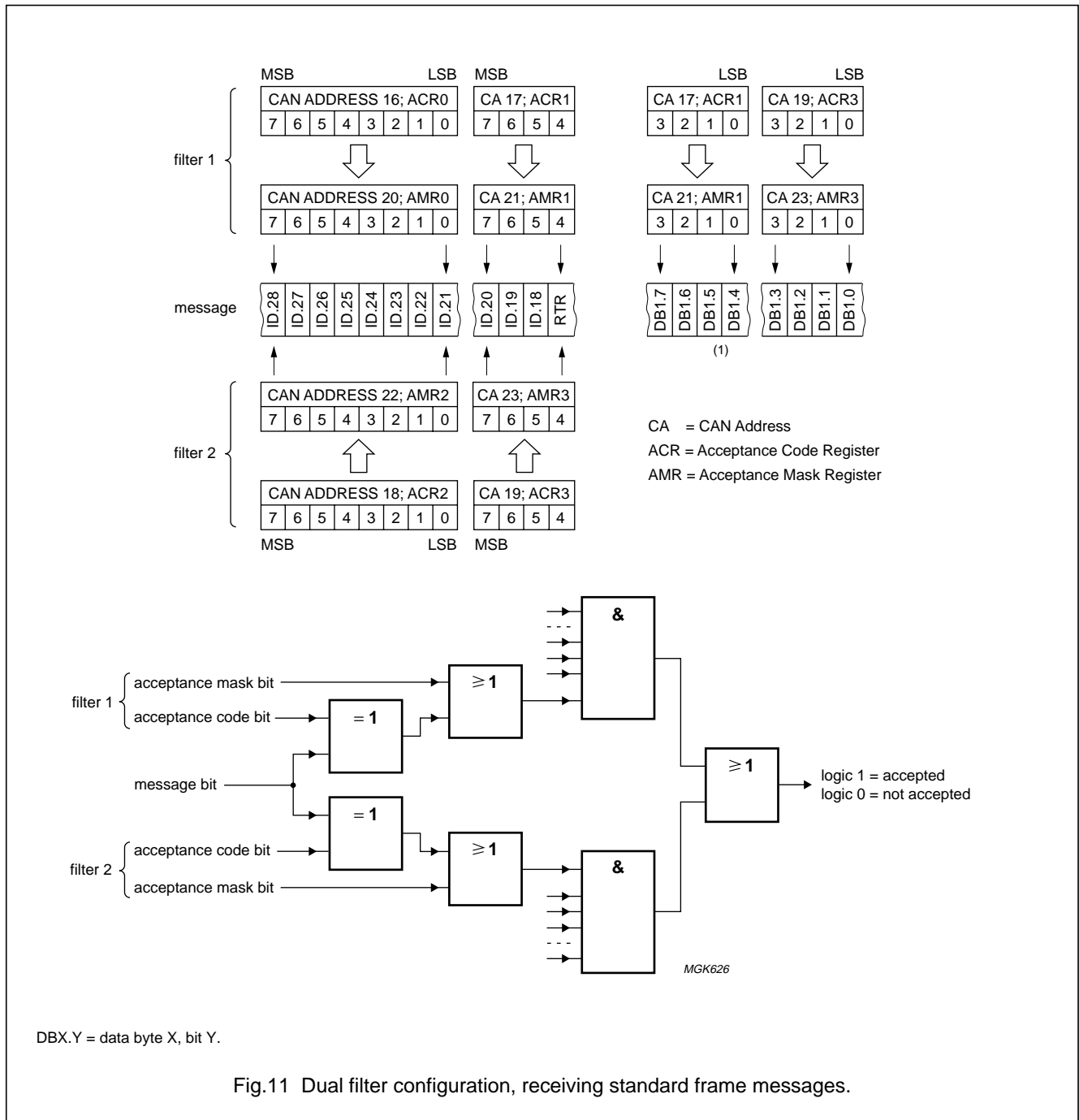

Fig.11 Dual filter configuration, receiving standard frame messages.

Stand-alone CAN controller

SJA1000

Extended frame: if an extended frame message is received, the two defined filters are looking identically. Both filters are comparing the first two bytes of the extended identifier range only.

For a successful reception of a message, all single bit comparisons of at least one complete filter have to indicate acceptance.

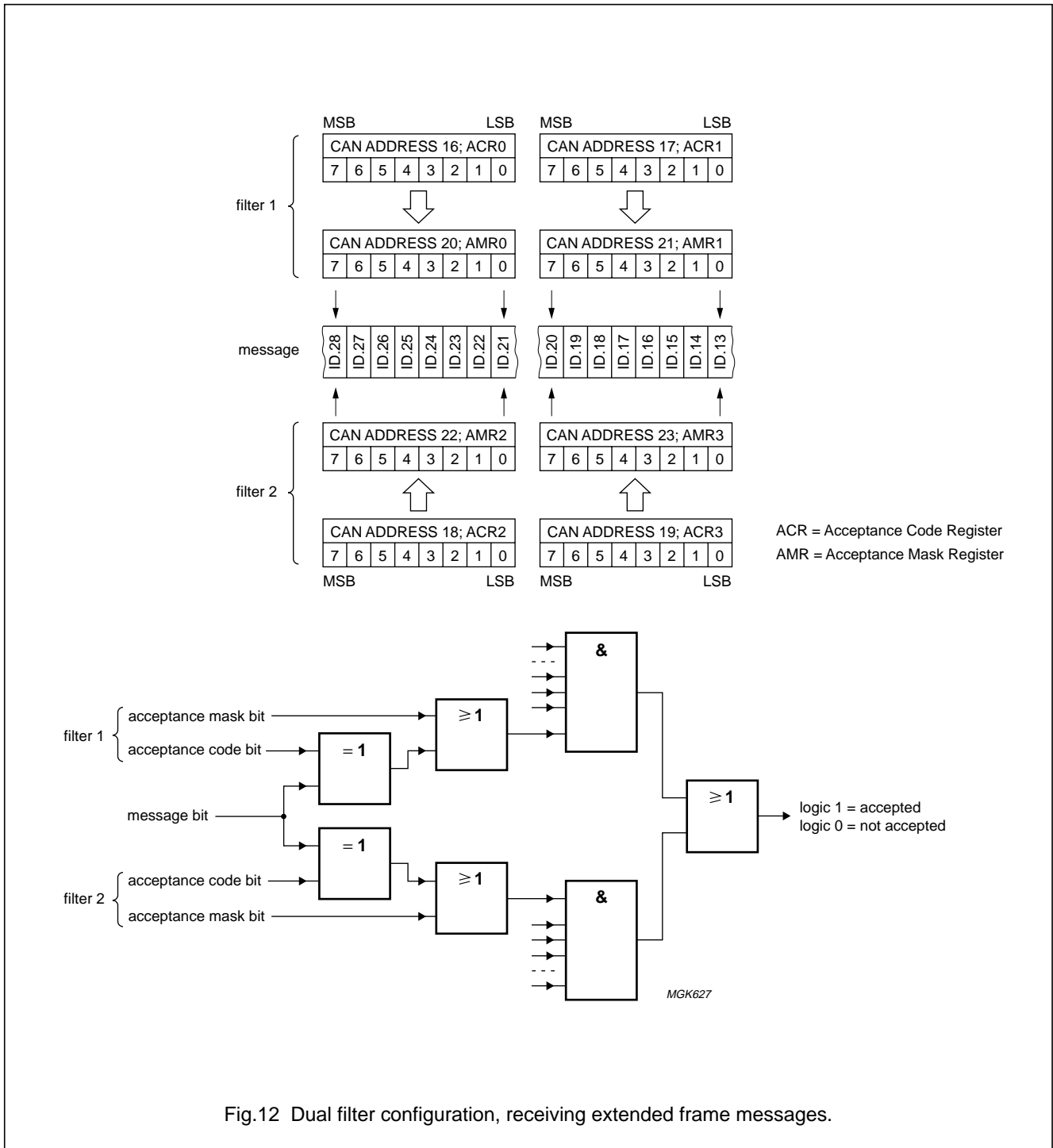

Fig.12 Dual filter configuration, receiving extended frame messages.

Stand-alone CAN controller

SJA1000

6.4.16 RX MESSAGE COUNTER (RMC)

The RMC register (CAN address 29) reflects the number of messages available within the RXFIFO. The value is incremented with each receive event and decremented by the release receive buffer command. After any reset event, this register is cleared.

Table 42 Bit interpretation of the RX message counter (RMC); CAN address 29

BIT 7	BIT 6	BIT 5	BIT 4	BIT 3	BIT 2	BIT 1	BIT 0
(0) ⁽¹⁾	(0) ⁽¹⁾	(0) ⁽¹⁾	RMC.4	RMC.3	RMC.2	RMC.1	RMC.0

Note

1. This bit cannot be written. During read-out of this register always a zero is given.

6.4.17 RX BUFFER START ADDRESS REGISTER (RBSA)

The RBSA register (CAN address 30) reflects the currently valid internal RAM address, where the first byte of the received message, which is mapped to the receive buffer window, is stored. With the help of this information it is possible to interpret the internal RAM contents.

The internal RAM address area begins at CAN address 32 and may be accessed by the CPU for reading and writing (writing in reset mode only).

Example: if RBSA is set to 24 (decimal), the current message visible in the receive buffer window (CAN address 16 to 28) is stored within the internal RAM beginning at RAM address 24. Because the RAM is also mapped directly to the CAN address space beginning at CAN address 32 (equal to RAM address 0) this message may also be accessed using CAN address 56 and the following bytes (CAN address = RBSA + 32 > 24 + 32 = 56).

If a message exceeds RAM address 63, it continues at RAM address 0.

The release receive buffer command is always given while there is at least one more message available within the FIFO. RBSA is updated to the beginning of the next message.

On hardware reset, this pointer is initialized to '00H'. Upon a software reset (setting of reset mode) this pointer keeps its old value, but the FIFO is cleared; this means that the RAM contents are not changed, but the next received (or transmitted) message will override the currently visible message within the receive buffer window.

The RX buffer start address register appears to the CPU as a read only memory in operating mode and as read/write memory in reset mode. It should be noted that a write access to RBSA takes effect first after the next positive edge of the internal clock frequency, which is half of the external oscillator frequency.

Table 43 Bit interpretation of the RX buffer start address register (RBSA); CAN address 30

BIT 7	BIT 6	BIT 5	BIT 4	BIT 3	BIT 2	BIT 1	BIT 0
(0) ⁽¹⁾	(0) ⁽¹⁾	RBSA.5	RBSA.4	RBSA.3	RBSA.2	RBSA.1	RBSA.0

Note

1. This bit cannot be written. During read-out of this register always a zero is given.

Stand-alone CAN controller

SJA1000

6.5 Common registers

6.5.1 BUS TIMING REGISTER 0 (BTR0)

The contents of the bus timing register 0 defines the values of the Baud Rate Prescaler (BRP) and the Synchronization Jump Width (SJW). This register can be accessed (read/write) if the reset mode is active.

In operating mode this register is read only, if the PeliCAN mode is selected. In BasicCAN mode a 'FFH' is reflected.

Table 44 Bit interpretation of bus timing register 0 (BTR0); CAN address 6

BIT 7	BIT 6	BIT 5	BIT 4	BIT 3	BIT 2	BIT 1	BIT 0
SJW.1	SJW.0	BRP.5	BRP.4	BRP.3	BRP.2	BRP.1	BRP.0

6.5.1.1 Baud Rate Prescaler (BRP)

The period of the CAN system clock t_{scl} is programmable and determines the individual bit timing. The CAN system clock is calculated using the following equation:

$$t_{scl} = 2 \times t_{CLK} \times (32 \times BRP.5 + 16 \times BRP.4 + 8 \times BRP.3 + 4 \times BRP.2 + 2 \times BRP.1 + BRP.0 + 1)$$

where t_{CLK} = time period of the XTAL frequency = $\frac{1}{f_{XTAL}}$

6.5.1.2 Synchronization Jump Width (SJW)

To compensate for phase shifts between clock oscillators of different bus controllers, any bus controller must re-synchronize on any relevant signal edge of the current transmission. The synchronization jump width defines the maximum number of clock cycles a bit period may be shortened or lengthened by one re-synchronization:

$$t_{SJW} = t_{scl} \times (2 \times SJW.1 + SJW.0 + 1)$$

6.5.2 BUS TIMING REGISTER 1 (BTR1)

The contents of bus timing register 1 defines the length of the bit period, the location of the sample point and the number of samples to be taken at each sample point. This register can be accessed (read/write) if the reset mode is active.

In operating mode, this register is read only, if the PeliCAN mode is selected. In BasicCAN mode a 'FFH' is reflected.

Table 45 Bit interpretation of bus timing register 1 (BTR1); CAN address 7

BIT 7	BIT 6	BIT 5	BIT 4	BIT 3	BIT 2	BIT 1	BIT 0
SAM	TSEG2.2	TSEG2.1	TSEG2.0	TSEG1.3	TSEG1.2	TSEG1.1	TSEG1.0

6.5.2.1 Sampling (SAM)

BIT	VALUE	FUNCTION
SAM	1	triple; the bus is sampled three times; recommended for low/medium speed buses (class A and B) where filtering spikes on the bus line is beneficial
	0	single; the bus is sampled once; recommended for high speed buses (SAE class C)

Stand-alone CAN controller

SJA1000

6.5.2.2 Time Segment 1 (TSEG1) and Time Segment 2 (TSEG2)

TSEG1 and TSEG2 determine the number of clock cycles per bit period and the location of the sample point, where:

$$t_{\text{SYNCSEG}} = 1 \times t_{\text{scl}}$$

$$t_{\text{TSEG1}} = t_{\text{scl}} \times (8 \times \text{TSEG1.3} + 4 \times \text{TSEG1.2} + 2 \times \text{TSEG1.1} + \text{TSEG1.0} + 1)$$

$$t_{\text{TSEG2}} = t_{\text{scl}} \times (4 \times \text{TSEG2.2} + 2 \times \text{TSEG2.1} + \text{TSEG2.0} + 1)$$

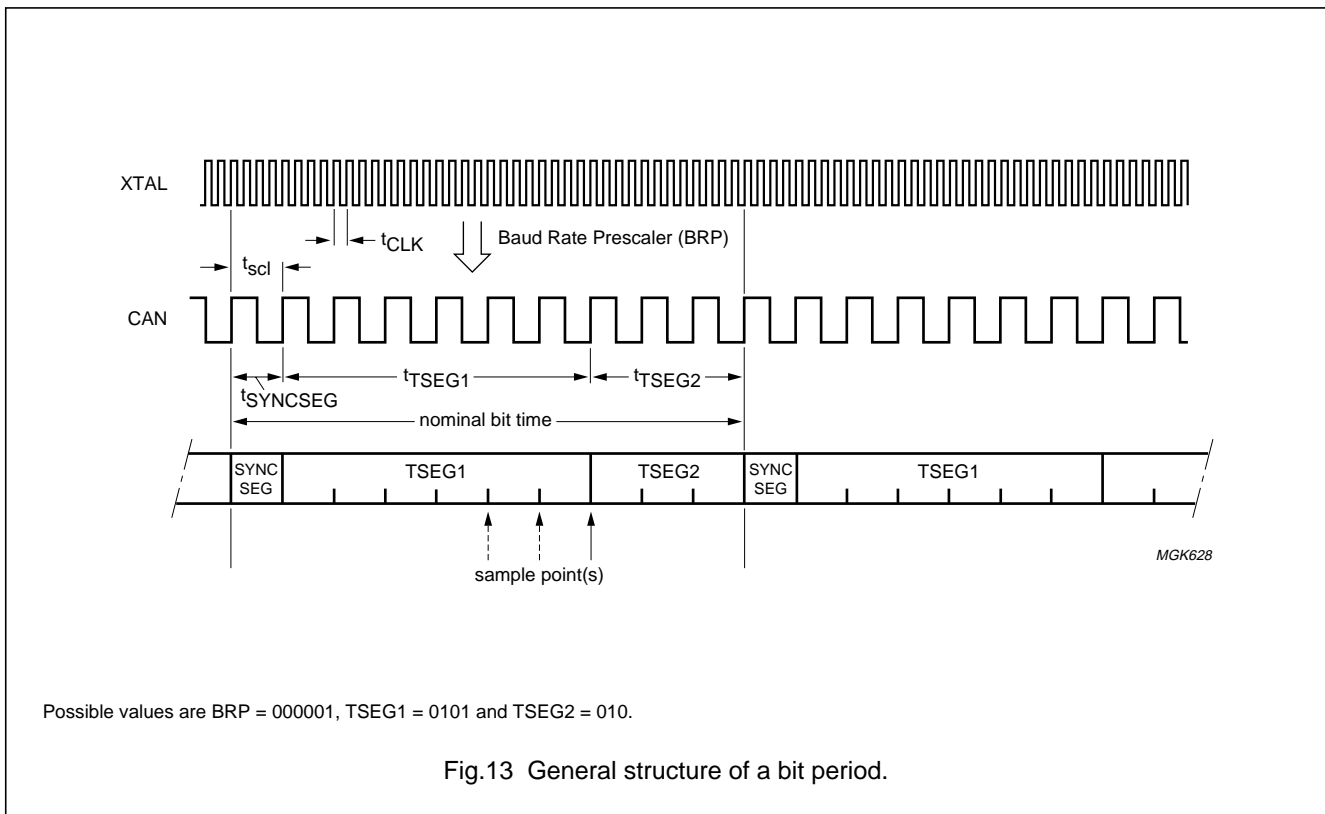

6.5.3 OUTPUT CONTROL REGISTER (OCR)

The output control register allows the set-up of different output driver configurations under software control.

This register may be accessed (read/write) if the reset mode is active. In operating mode, this register is read only, if the PeliCAN mode is selected. In BasicCAN mode a 'FFH' is reflected.

Table 46 Bit interpretation of the output control register (OCR); CAN address 8

BIT 7	BIT 6	BIT 5	BIT 4	BIT 3	BIT 2	BIT 1	BIT 0
OCTP1	OCTN1	OCPOL1	OCTP0	OCTN0	OCPOL0	OCMODE1	OCMODE0

Stand-alone CAN controller

SJA1000

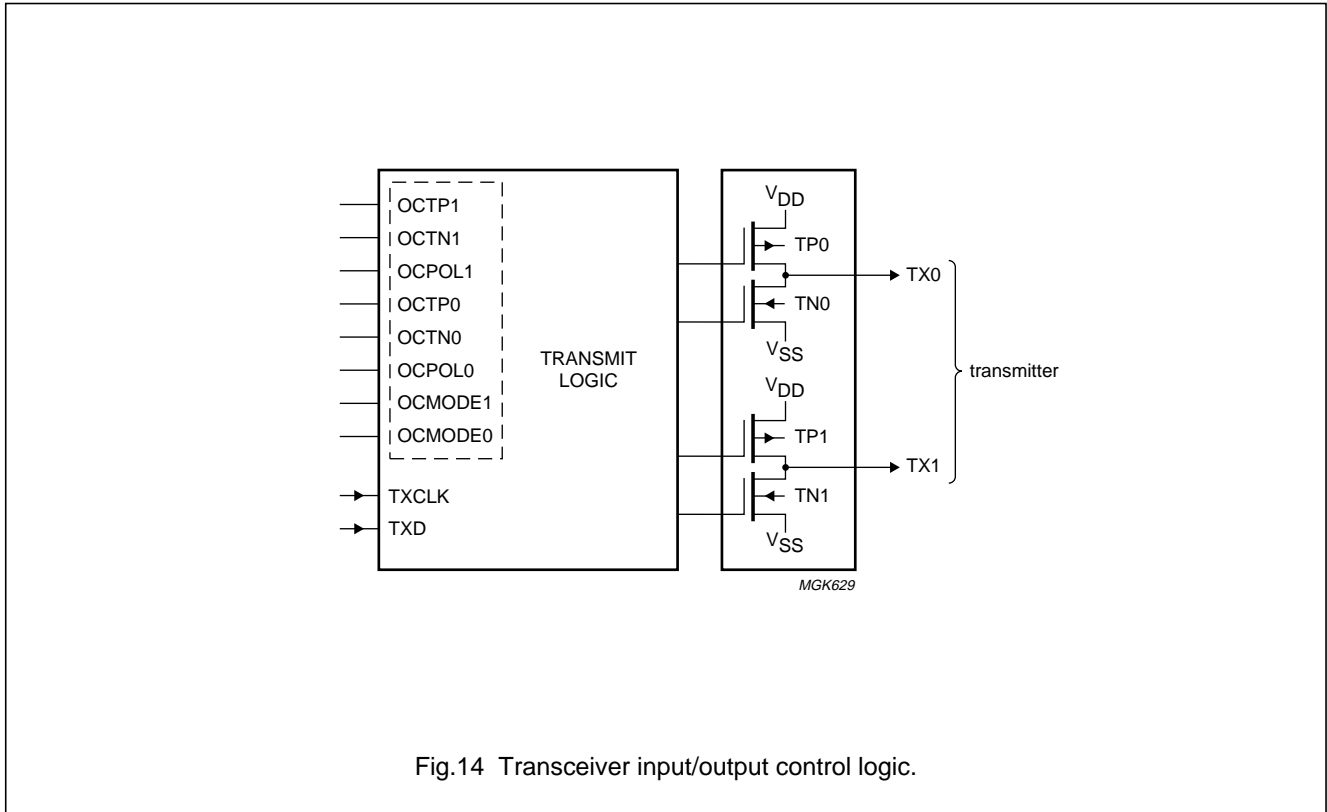

Fig.14 Transceiver input/output control logic.

If the SJA1000 is in the sleep mode a recessive level is output on the TX0 and TX1 pins with respect to the contents within the output control register. If the SJA1000 is in the reset state (reset request = HIGH) or the external reset pin \overline{RST} is pulled LOW the outputs TX0 and TX1 are floating.

The transmit output stage is able to operate in different modes. Table 47 shows the output control register settings.

Table 47 Interpretation of OCMODE bits

OCMODE1	OCMODE0	DESCRIPTION
0	0	bi-phase output mode
0	1	test output mode; note 1
1	0	normal output mode
1	1	clock output mode

Note

- In test output mode TXn will reflect the bit, detected on RX pins, with the next positive edge of the system clock. TN1, TN0, TP1 and TP0 are configured in accordance with the setting of OCR.

6.5.3.1 Normal output mode

In normal output mode the bit sequence (TXD) is sent via TX0 and TX1. The voltage levels on the output driver pins TX0 and TX1 depend on both the driver characteristic programmed by OCTPx, OCTNx (float, pull-up, pull-down, push-pull) and the output polarity programmed by OCPOLx.

Stand-alone CAN controller

SJA1000

6.5.3.2 Clock output mode

For the TX0 pin this is the same as in normal output mode. However, the data stream to TX1 is replaced by the transmit clock (TXCLK). The rising edge of the transmit clock (non-inverted) marks the beginning of a bit period. The clock pulse width is $1 \times t_{scl}$.

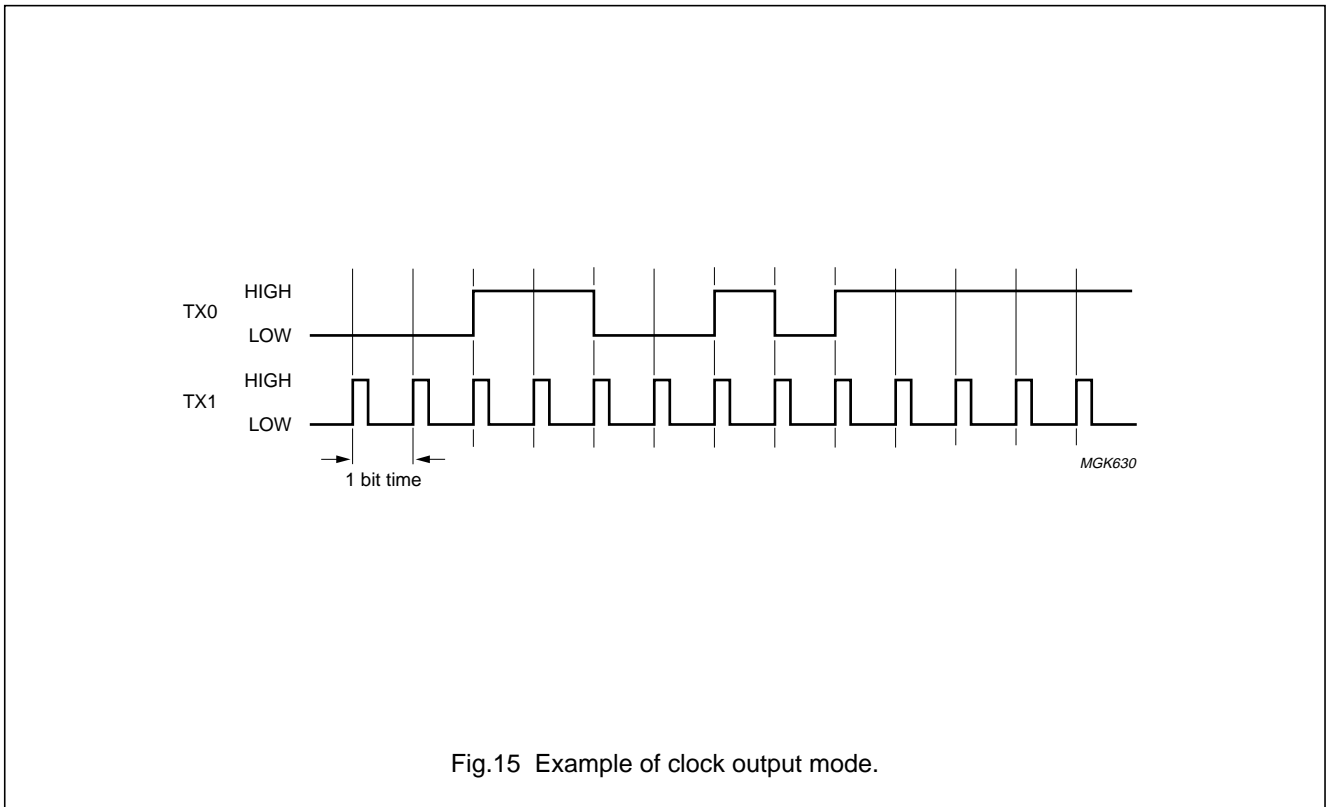

Fig.15 Example of clock output mode.

6.5.3.3 Bi-phase output mode

In contrast to the normal output mode the bit representation is time variant and toggled. If the bus controllers are galvanically decoupled from the bus line by a transformer, the bit stream is not allowed to contain a DC component. This is achieved by the following scheme.

During recessive bits all outputs are deactivated (floating). Dominant bits are sent with alternating levels on TX0 and TX1, i.e. the first dominant bit is sent on TX0, the second is sent on TX1, and the third one is sent on TX0 again, and so on. One possible configuration example of the bi-phase output mode timing is shown in Fig.16.

Stand-alone CAN controller

SJA1000

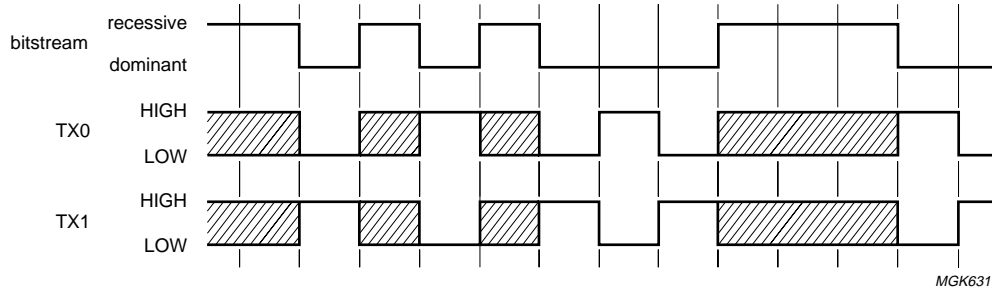

Fig.16 Bi-phase output mode example (output control register = F8H).

6.5.3.4 Test output mode

In test output mode the level connected to RX is reflected at TXn with the next positive edge of the system clock $\frac{f_{osc}}{2}$ corresponding to the programmed polarity in the output control register.

Table 48 shows the relationship between the bits of the output control register and the output pins TX0 and TX1.

Stand-alone CAN controller

SJA1000

Table 48 Output pin configuration; note 1

DRIVE	TXD	OCTPX	OCTNX	OCPOLX	TPX ⁽²⁾	TNX ⁽³⁾	TXX ⁽⁴⁾
Float	X	0	0	X	off	off	float
Pull-down	0	0	1	0	off	on	LOW
	1	0	1	0	off	off	float
	0	0	1	1	off	off	float
	1	0	1	1	off	on	LOW
Pull-up	0	1	0	0	off	off	float
	1	1	0	0	on	off	HIGH
	0	1	0	1	on	off	HIGH
	1	1	0	1	off	off	float
Push-pull	0	1	1	0	off	on	LOW
	1	1	1	0	on	off	HIGH
	0	1	1	1	on	off	HIGH
	1	1	1	1	off	on	LOW

Notes

1. X = don't care.
2. TPX is the on-chip output transistor X, connected to V_{DD} .
3. TNX is the on-chip output transistor X, connected to V_{SS} .
4. TXX is the serial output level on pin TX0 or TX1. It is required that the output level on the CAN-bus line is dominant when TXD = 0 and recessive when TXD = 1.

The bit sequence (TXD) is sent via TX0 and TX1. The voltage levels on the output driver pins depends on both the driver characteristics programmed by OCTP, OCTN (float, pull-up, pull-down, push-pull) and the output polarity programmed by OCPOL.

6.5.4 CLOCK DIVIDER REGISTER (CDR)

The clock divider register controls the CLKOUT frequency for the microcontroller and allows to deactivate the CLKOUT pin. Additionally a dedicated receive interrupt pulse on TX1, a receive comparator bypass and the

selection between BasicCAN mode and PeliCAN mode is made here. The default state of the register after hardware reset is divide-by-12 for Motorola mode (00000101) and divide-by-2 for Intel mode (00000000).

On software reset (reset request/reset mode) this register is not influenced.

The reserved bit (CDR.4) will always reflect a logic 0. The application software should always write a logic 0 to this bit in order to be compatible with future features, which may be 1-active using this bit.

Table 49 Bit interpretation of the clock divider register (CDR); CAN address 31

BIT 7	BIT 6	BIT 5	BIT 4	BIT 3	BIT 2	BIT 1	BIT 0
CAN mode	CBP	RXINTEN	(0) ⁽¹⁾	clock off	CD.2	CD.1	CD.0

Note

1. This bit cannot be written. During read-out of this register always a zero is given.

Stand-alone CAN controller

SJA1000

6.5.4.1 CD.2 to CD.0

The bits CD.2 to CD.0 are accessible without restrictions in reset mode as well as in operating mode. These bits are used to define the frequency at the external CLKOUT pin. For an overview of selectable frequencies see Table 50.

Table 50 CLKOUT frequency selection; note 1

CD.2	CD.1	CD.0	CLKOUT FREQUENCY
0	0	0	$\frac{f_{osc}}{2}$
0	0	1	$\frac{f_{osc}}{4}$
0	1	0	$\frac{f_{osc}}{6}$
0	1	1	$\frac{f_{osc}}{8}$
1	0	0	$\frac{f_{osc}}{10}$
1	0	1	$\frac{f_{osc}}{12}$
1	1	0	$\frac{f_{osc}}{14}$
1	1	1	f_{osc}

Note

1. f_{osc} is the frequency of the external oscillator (XTAL).

6.5.4.2 Clock off

Setting this bit allows the external CLKOUT pin of the SJA1000 to be disabled. A write access is possible only in reset mode. If this bit is set, CLKOUT is LOW during sleep mode, otherwise it is HIGH.

6.5.4.3 RXINTEN

This bit allows the TX1 output to be used as a dedicated receive interrupt output. When a received message has passed the acceptance filter successfully, a receive interrupt pulse with the length of one bit time is always output at the TX1 pin (during the last bit of end of frame). The transmit output stage should operate in normal output mode. The polarity and output drive are programmable via the output control register (see also Section 6.5.3). A write access is only possible in reset mode.

6.5.4.4 CBP

Setting of CDR.6 allows to bypass the CAN input comparator and is only possible in reset mode. This is useful in the event that the SJA1000 is connected to an external transceiver circuit. The internal delay of the SJA1000 is reduced, which will result in a longer maximum possible bus length. If CBP is set, only RX0 is active. The unused RX1 input should be connected to a defined level (e.g. V_{SS}).

6.5.4.5 CAN mode

CDR.7 defines the CAN mode. If CDR.7 is at logic 0 the CAN controller operates in BasicCAN mode. If set to logic 1 the CAN controller operates in PeliCAN mode. Write access is only possible in reset mode.

Stand-alone CAN controller

SJA1000

7 LIMITING VALUESIn accordance with the Absolute Maximum Rating System (IEC 134); all voltages referenced to V_{SS} .

SYMBOL	PARAMETER	CONDITIONS	MIN.	MAX.	UNIT
V_{DD}	supply voltage		-0.5	+6.5	V
I_I, I_O	input/output current on all pins except TX0 and TX1		-	± 4	mA
$I_{OT(sink)}$	sink current of TX0 and TX1 together	note 1	-	30	mA
$I_{OT(source)}$	source current of TX0 and TX1 together	note 1	-	-20	mA
T_{amb}	operating ambient temperature		-40	+125	$^{\circ}C$
T_{stg}	storage temperature		-65	+150	$^{\circ}C$
P_{tot}	total power dissipation	note 2	-	1.0	W
V_{esd}	electrostatic discharge on all pins	note 3	-1500	+1500	V
		note 4	-200	+200	V

Notes

- I_{OT} is allowed in case of a bus failure condition because then the TX outputs are switched off automatically after a short time (bus-off state). During normal operation I_{OT} is a peak current, permitted for $t < 100$ ms. The average output current must not exceed 10 mA for each TX output.
- This value is based on the maximum allowable die temperature and the thermal resistance of the package, not on device power consumption.
- Human body model: equivalent to discharging a 100 pF capacitor through a 1.5 k Ω resistor.
- Machine model: equivalent to discharging a 200 pF capacitor through a 25 Ω plus 2.5 μH circuit.

8 THERMAL CHARACTERISTICS

SYMBOL	PARAMETER	CONDITION	VALUE	UNIT
$R_{th(j-a)}$	thermal resistance from junction to ambient	in free air	67	K/W

9 DC CHARACTERISTICS $V_{DD} = 5$ V ($\pm 10\%$); $V_{SS} = 0$ V; $T_{amb} = -40$ to $+125$ $^{\circ}C$; all voltages referenced to V_{SS} ; unless otherwise specified.

SYMBOL	PARAMETER	CONDITIONS	MIN.	MAX.	UNIT
Supplies					
V_{DD}	supply voltage		4.5	5.5	V
I_{DD}	operating supply current	$f_{osc} = 24$ MHz; note 1	-	15	mA
I_{sm}	sleep mode supply current	oscillator inactive; note 2	-	40	μA

Stand-alone CAN controller

SJA1000

SYMBOL	PARAMETER	CONDITIONS	MIN.	MAX.	UNIT
Inputs					
V_{IL1}	LOW-level input voltage on pins ALE/AS, \overline{CS} , $\overline{RD/E}$, \overline{WR} and MODE		-0.5	+0.8	V
V_{IL2}	LOW-level input voltage on pins XTAL1 and \overline{INT}		-	$0.3V_{DD}$	V
V_{IL3}	LOW-level input voltage on pins \overline{RST} , AD0 to AD7 and RX0 ⁽⁵⁾		-0.5	+0.6	V
V_{IH1}	HIGH-level input voltage on pins ALE/AS, \overline{CS} , $\overline{RD/E}$, \overline{WR} and MODE		2.0	$V_{DD} + 0.5$	V
V_{IH2}	HIGH-level input voltage on pins XTAL1 and \overline{INT}		$0.7V_{DD}$	-	V
V_{IH3}	HIGH-level input voltage on pins \overline{RST} , AD0 to AD7 and RX0 ⁽⁵⁾		2.4	$V_{DD} + 0.5$	V
hy_{RST}	input hysteresis at pins \overline{RST} , AD0 to AD7 and RX0 ⁽⁵⁾		500	-	mV
I_{LI}	input leakage current on all pins except XTAL1, RX0 and RX1	$0.45\text{ V} < V_{I(D)} < V_{DD}$; note 3	-	± 2	μA
Outputs					
V_{OL}	LOW-level output voltage for pins AD0 to AD7, CLKOUT and \overline{INT}	$I_{OL} = 4\text{ mA}$	-	0.4	V
V_{OH}	HIGH-level output voltage for pins AD0 to AD7 and CLKOUT	$I_{OH} = -4\text{ mA}$	$V_{DD} - 0.4$	-	V
CAN input comparator (see also Fig.22)					
$V_{th(i)(diff)}$	differential input threshold voltage	$V_{DD} = 5\text{ V} \pm 10\%$; $1.4\text{ V} < V_{I(RX)} < V_{DD} - 1.4\text{ V}$; notes 4 and 6	-	± 32	mV
V_{hys}	hysteresis voltage		8	30	mV
I_I	input current		-	± 400	nA
CAN output driver					
$V_{OL(TX)}$	LOW-level output voltage at pins TX0 and TX1	$V_{DD} = 5\text{ V} \pm 10\%$	-	0.05	V
		$I_O = 1.2\text{ mA}$; note 6	-	0.4	V
$V_{OH(TX)}$	HIGH-level output voltage at pins TX0 and TX1	$V_{DD} = 5\text{ V} \pm 10\%$	$V_{DD} - 0.05$	-	V
		$I_O = 1.2\text{ mA}$; note 6	$V_{DD} - 0.4$	-	V

Notes

- AD0 to AD7 = ALE = \overline{RD} = \overline{WR} = \overline{CS} = V_{DD} ; \overline{RST} = MODE = V_{SS} ; RX0 = 2.7 V; RX1 = 2.3 V; XTAL1 = 0.5 V or $V_{DD} - 0.5\text{ V}$; all outputs unloaded.
- AD0 to AD7 = ALE = \overline{RD} = \overline{WR} = \overline{INT} = \overline{RST} = \overline{CS} = MODE = RX0 = V_{DD} ; RX1 = XTAL1 = V_{SS} ; all outputs unloaded.
- $V_{I(D)}$ = input voltage on all digital input pins.
- $V_{I(RX)}$ = input voltage on pins RX0 and RX1.
- Only if comparator bypass mode is active.
- Not tested during production.

Stand-alone CAN controller

SJA1000

10 AC CHARACTERISTICS

$V_{DD} = 5\text{ V} \pm 10\%$; $V_{SS} = 0\text{ V}$; $C_L = 50\text{ pF}$ (output pins); $T_{amb} = -40\text{ to }+125\text{ }^\circ\text{C}$; unless otherwise specified; note 1.

SYMBOL	PARAMETER	CONDITIONS	MIN.	MAX.	UNIT
f_{osc}	oscillator frequency		–	24	MHz
$t_{su(A-AL)}$	address set-up to ALE/AS LOW		8	–	ns
$t_{h(AL-A)}$	address hold after ALE LOW		2	–	ns
$t_{W(AL)}$	ALE/AS pulse width		8	–	ns
t_{RLQV}	\overline{RD} LOW to valid data output	Intel mode	–	50	ns
t_{EHQV}	E HIGH to valid data output	Motorola mode	–	50	ns
t_{RHDZ}	data float after \overline{RD} HIGH	Intel mode	–	30	ns
t_{ELDZ}	data float after E LOW	Motorola mode	–	30	ns
t_{DVWH}	input data valid to \overline{WR} HIGH	Intel mode	8	–	ns
t_{WHDX}	input data hold after \overline{WR} HIGH	Intel mode	8	–	ns
t_{WHLH}	\overline{WR} HIGH to next ALE HIGH		15	–	ns
t_{ELAH}	E LOW to next AS HIGH	Motorola mode	15	–	ns
$t_{su(i)(D-EL)}$	input data set-up to E LOW	Motorola mode	8	–	ns
$t_{h(i)(EL-D)}$	input data hold after E LOW	Motorola mode	8	–	ns
t_{LLWL}	ALE LOW to \overline{WR} LOW	Intel mode	10	–	ns
t_{LLRL}	ALE LOW to \overline{RD} LOW	Intel mode	10	–	ns
t_{LLEH}	AS LOW to E HIGH	Motorola mode	10	–	ns
$t_{su(R-EH)}$	set-up time of RD/ \overline{WR} to E HIGH	Motorola mode	5	–	ns
$t_{W(W)}$	\overline{WR} pulse width	Intel mode	20	–	ns
$t_{W(R)}$	\overline{RD} pulse width	Intel mode	40	–	ns
$t_{W(E)}$	E pulse width	Motorola mode	40	–	ns
t_{CLWL}	\overline{CS} LOW to \overline{WR} LOW	Intel mode	0	–	ns
t_{CLRL}	\overline{CS} LOW to \overline{RD} LOW	Intel mode	0	–	ns
t_{CLEH}	\overline{CS} LOW to E HIGH	Motorola mode	0	–	ns
t_{WHCH}	\overline{WR} HIGH to \overline{CS} HIGH	Intel mode	0	–	ns
t_{RHCH}	\overline{RD} HIGH to \overline{CS} HIGH	Intel mode	0	–	ns
t_{ELCH}	E LOW to \overline{CS} HIGH	Motorola mode	0	–	ns
$t_{W(RST)}$	\overline{RST} pulse width		100	–	ns
Input comparator/output driver					
t_{SD}	sum of input and output delays	$V_{DD} = 5\text{ V} \pm 10\%$; $V_{DIF} = \pm 32\text{ mV}$; $1.4\text{ V} < V_{I(RX)} < V_{DD} - 1.4\text{ V}$; note 2	–	40	ns

Notes

- AC characteristics are not tested during production.
- The analog input comparator may be bypassed internally using the CBP bit in the clock divider register, if external transceiver circuitry is used. This results in reduced delays (<26 ns). $V_{I(RX)}$ = input voltage on pins RX0 and RX1.

Stand-alone CAN controller

SJA1000

10.1 AC timing diagrams

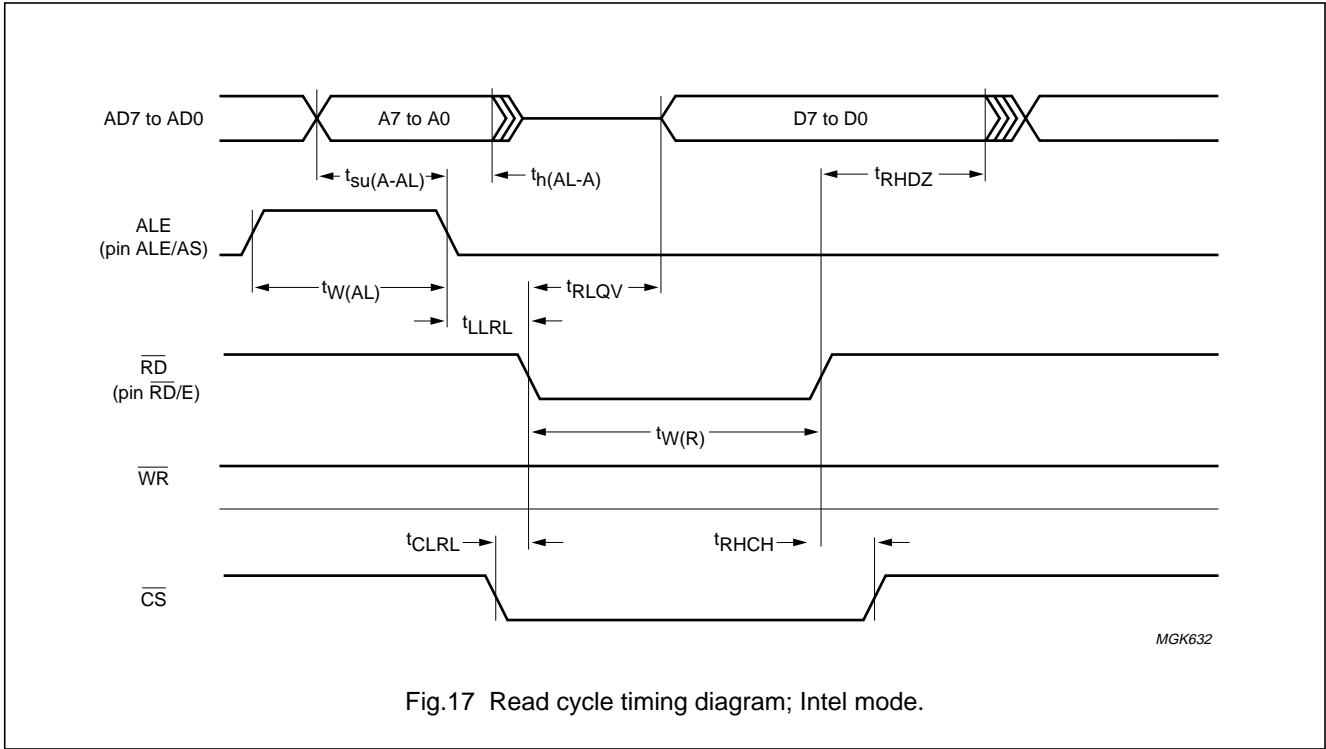

Fig.17 Read cycle timing diagram; Intel mode.

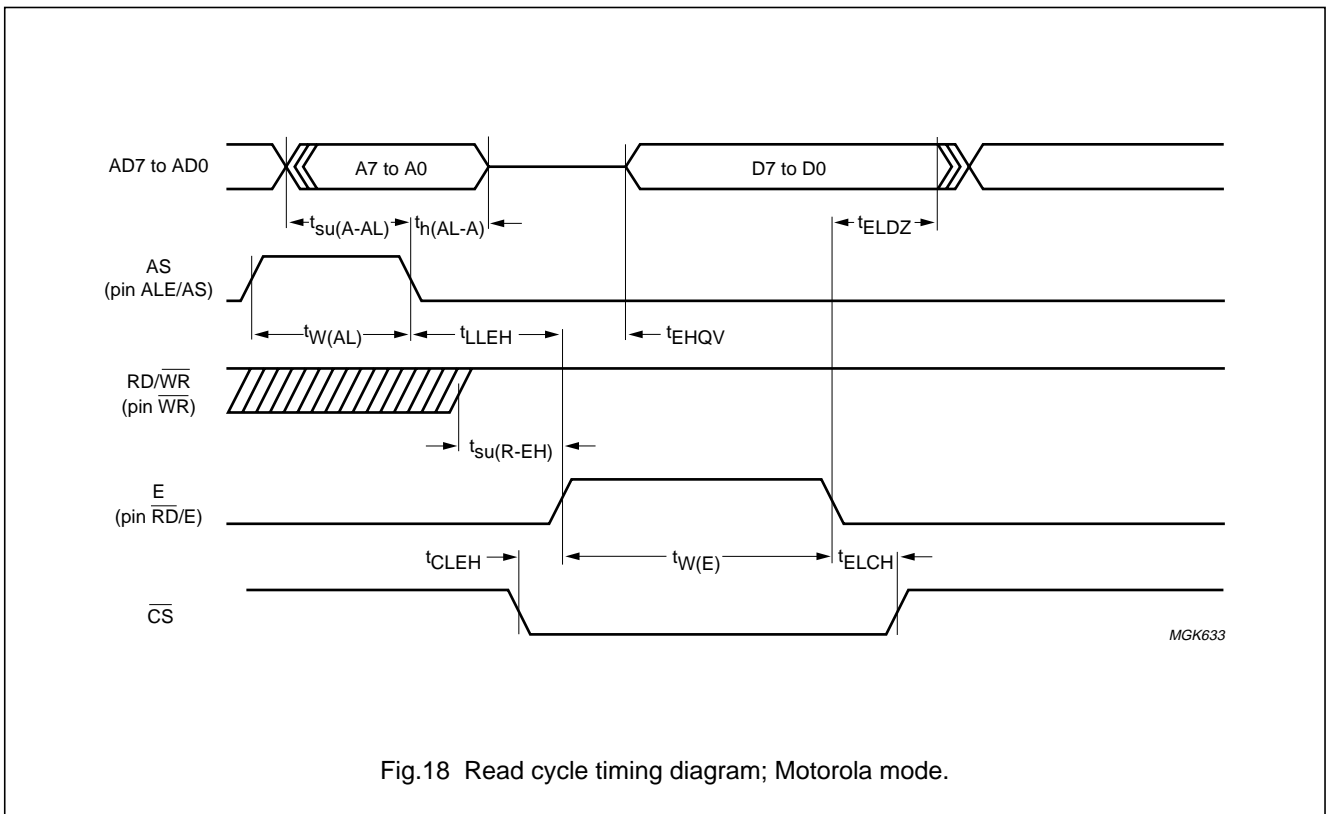
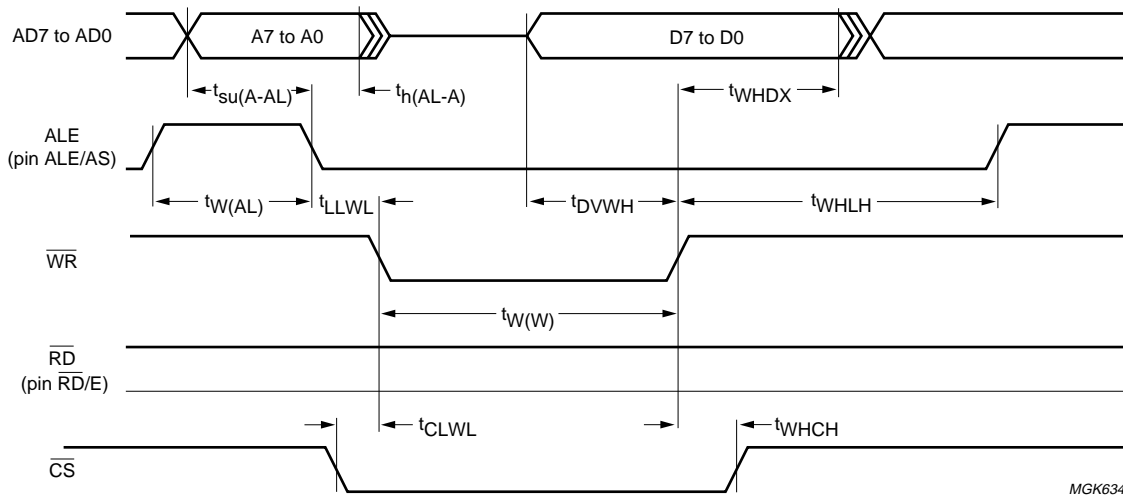

Fig.18 Read cycle timing diagram; Motorola mode.

Stand-alone CAN controller

SJA1000



MGK634

Fig.19 Write cycle timing diagram; Intel mode.

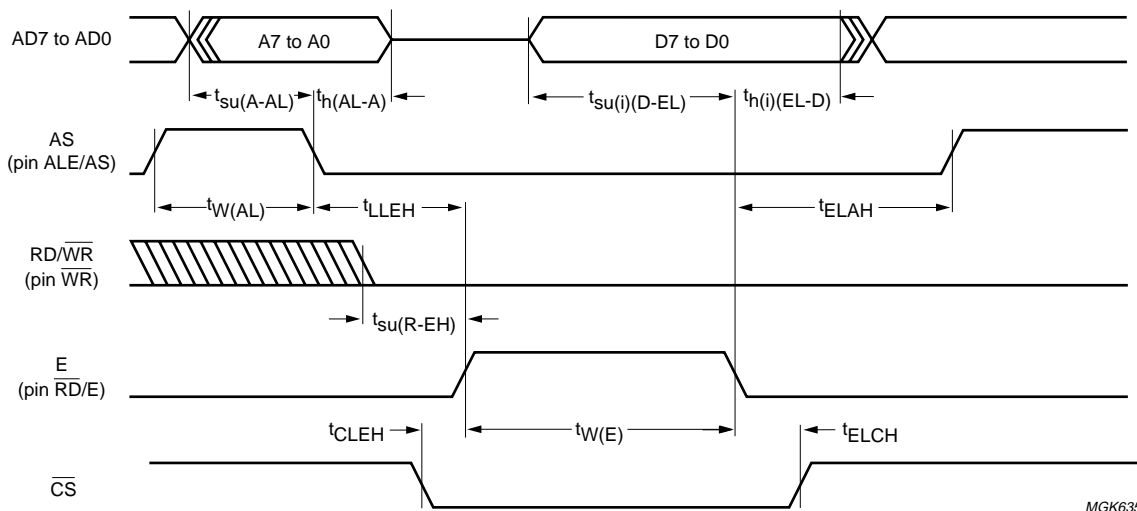

MGK635

Fig.20 Write cycle timing diagram; Motorola mode.

Stand-alone CAN controller

SJA1000

10.2 Additional AC information

To provide optimum noise immunity under worst case conditions, the chip is powered by three separate pins and grounded by three separate pins.

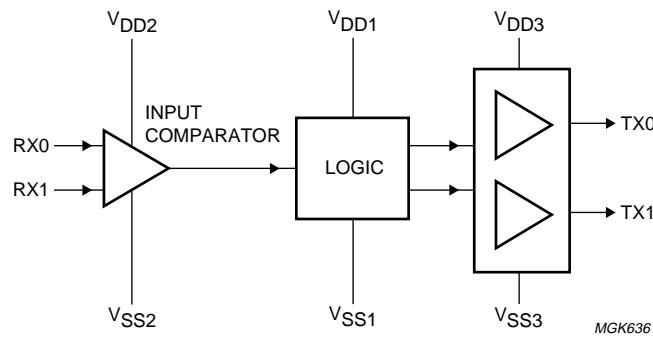
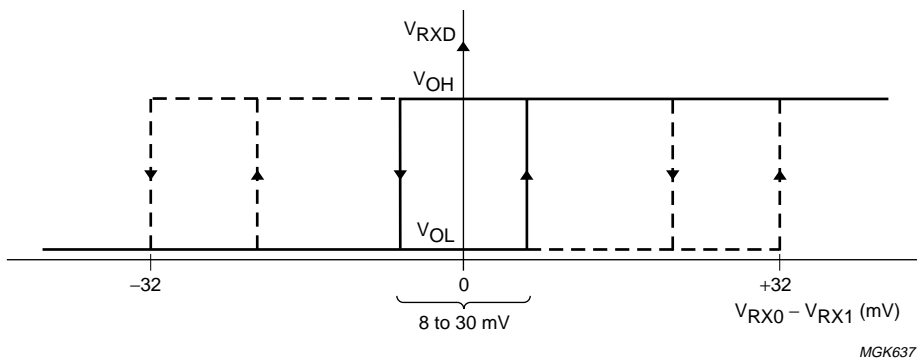

Fig.21 Optimized noise immunity block diagram.



Absolute input voltage at RX pins: $1.4\text{ V} < V_{RX} < V_{DD} - 1.4\text{ V}$.

The minimum differential input voltage at the RX pins has to be greater than $\pm 32\text{ mV}$ under all conditions to obtain a defined RXD output level.

Fig.22 Input comparator definitions.

Stand-alone CAN controller

SJA1000

11 PACKAGE OUTLINES

DIP28: plastic dual in-line package; 28 leads (600 mil)

SOT117-1

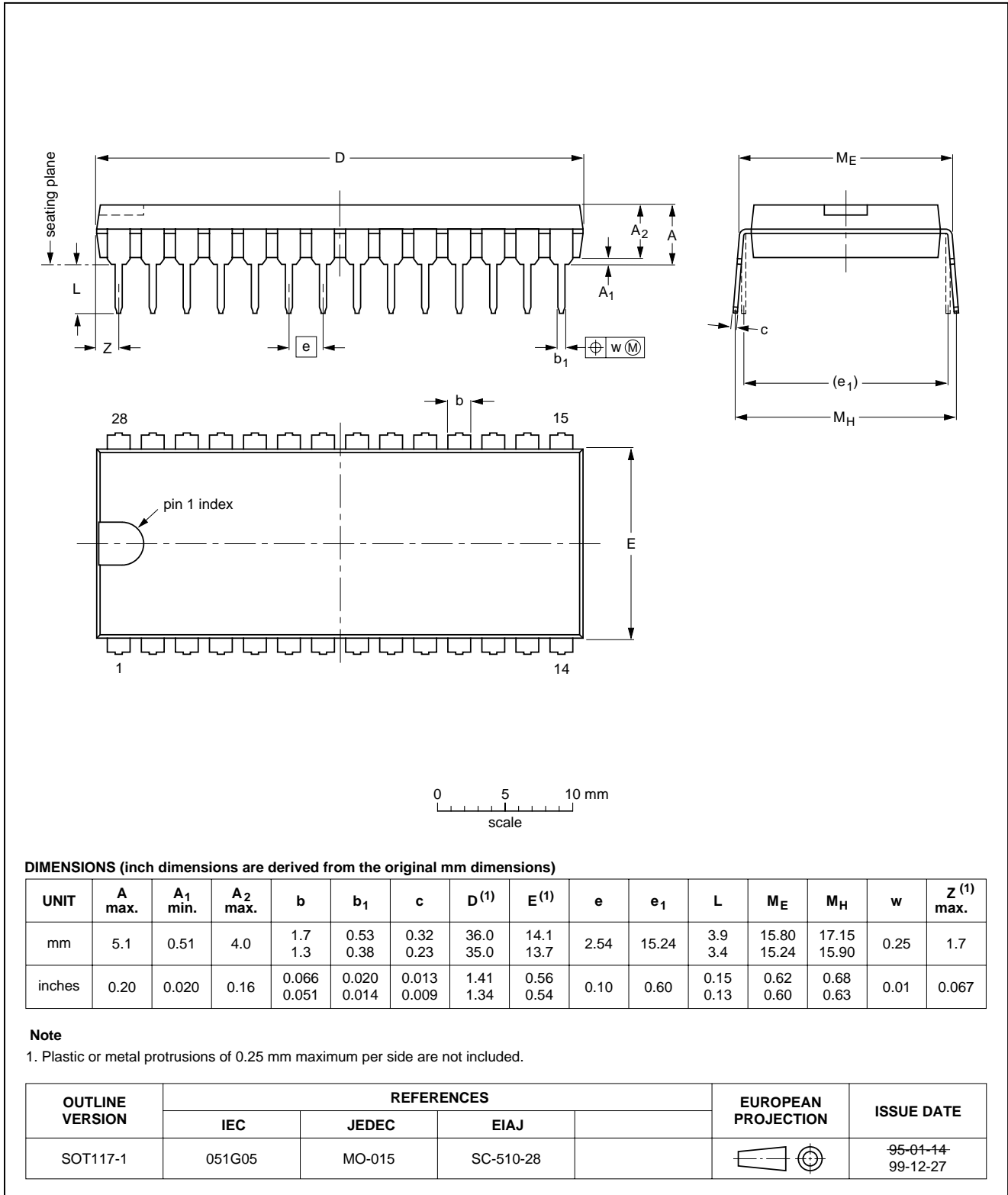

Stand-alone CAN controller

SJA1000

SO28: plastic small outline package; 28 leads; body width 7.5 mm

SOT136-1

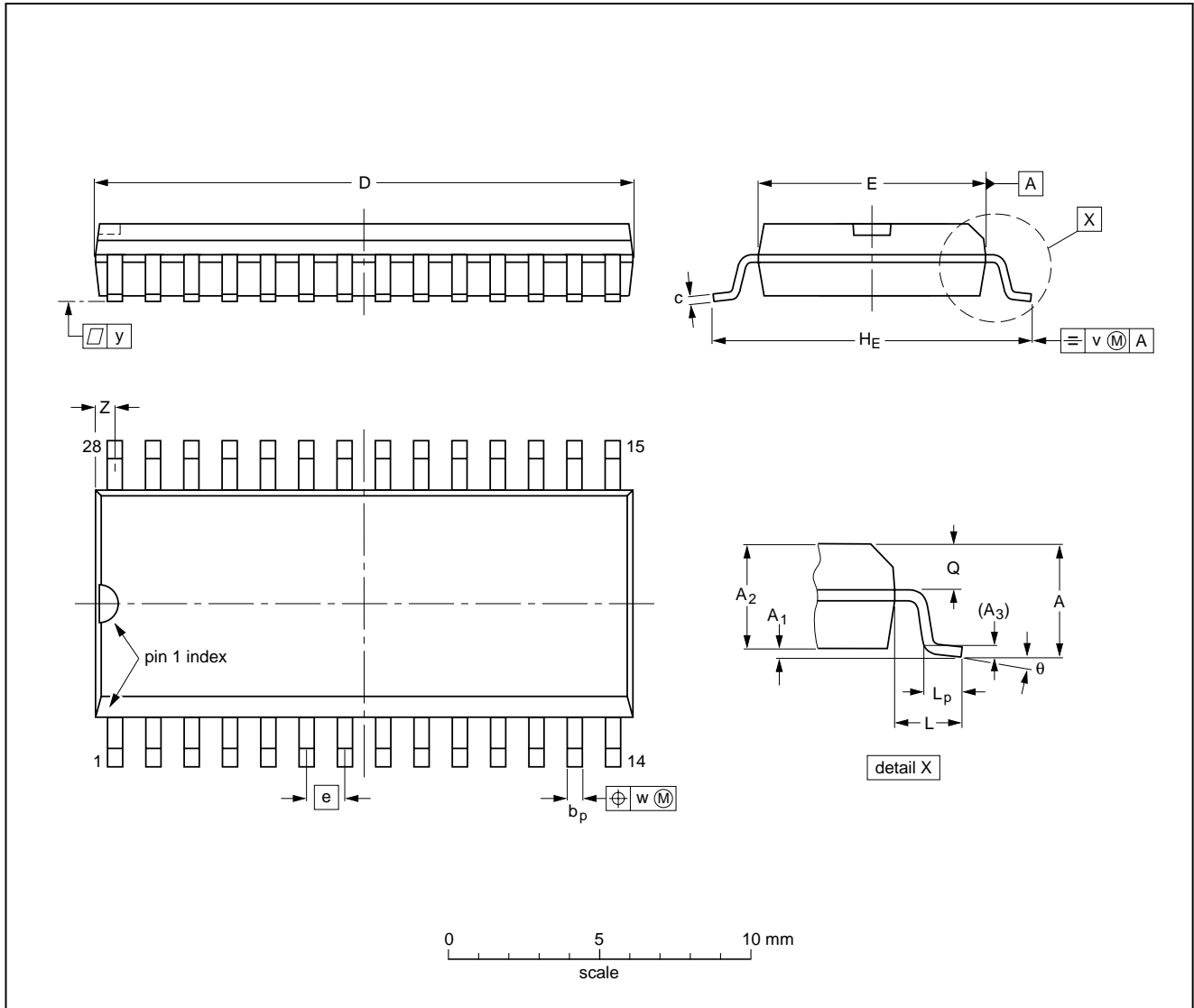

DIMENSIONS (inch dimensions are derived from the original mm dimensions)

UNIT	A max.	A ₁	A ₂	A ₃	b _p	c	D ⁽¹⁾	E ⁽¹⁾	e	H _E	L	L _p	Q	v	w	y	Z ⁽¹⁾	θ
mm	2.65	0.30 0.10	2.45 2.25	0.25	0.49 0.36	0.32 0.23	18.1 17.7	7.6 7.4	1.27	10.65 10.00	1.4	1.1 0.4	1.1 1.0	0.25	0.25	0.1	0.9 0.4	8° 0°
inches	0.10	0.012 0.004	0.096 0.089	0.01	0.019 0.014	0.013 0.009	0.71 0.69	0.30 0.29	0.050	0.419 0.394	0.055	0.043 0.016	0.043 0.039	0.01	0.01	0.004	0.035 0.016	

Note

1. Plastic or metal protrusions of 0.15 mm maximum per side are not included.

OUTLINE VERSION	REFERENCES				EUROPEAN PROJECTION	ISSUE DATE
	IEC	JEDEC	EIAJ			
SOT136-1	075E06	MS-013				97-05-22 99-12-27

Stand-alone CAN controller

SJA1000

12 SOLDERING

12.1 Introduction

This text gives a very brief insight to a complex technology. A more in-depth account of soldering ICs can be found in our *"Data Handbook IC26; Integrated Circuit Packages"* (document order number 9398 652 90011).

There is no soldering method that is ideal for all IC packages. Wave soldering is often preferred when through-hole and surface mount components are mixed on one printed-circuit board. However, wave soldering is not always suitable for surface mount ICs, or for printed-circuit boards with high population densities. In these situations reflow soldering is often used.

12.2 Through-hole mount packages

12.2.1 SOLDERING BY DIPPING OR BY SOLDER WAVE

The maximum permissible temperature of the solder is 260 °C; solder at this temperature must not be in contact with the joints for more than 5 seconds. The total contact time of successive solder waves must not exceed 5 seconds.

The device may be mounted up to the seating plane, but the temperature of the plastic body must not exceed the specified maximum storage temperature ($T_{stg(max)}$). If the printed-circuit board has been pre-heated, forced cooling may be necessary immediately after soldering to keep the temperature within the permissible limit.

12.2.2 MANUAL SOLDERING

Apply the soldering iron (24 V or less) to the lead(s) of the package, either below the seating plane or not more than 2 mm above it. If the temperature of the soldering iron bit is less than 300 °C it may remain in contact for up to 10 seconds. If the bit temperature is between 300 and 400 °C, contact may be up to 5 seconds.

12.3 Surface mount packages

12.3.1 REFLOW SOLDERING

Reflow soldering requires solder paste (a suspension of fine solder particles, flux and binding agent) to be applied to the printed-circuit board by screen printing, stencilling or pressure-syringe dispensing before package placement.

Several methods exist for reflowing; for example, infrared/convection heating in a conveyor type oven. Throughput times (preheating, soldering and cooling) vary between 100 and 200 seconds depending on heating method.

Typical reflow peak temperatures range from 215 to 250 °C. The top-surface temperature of the packages should preferably be kept below 230 °C.

12.3.2 WAVE SOLDERING

Conventional single wave soldering is not recommended for surface mount devices (SMDs) or printed-circuit boards with a high component density, as solder bridging and non-wetting can present major problems.

To overcome these problems the double-wave soldering method was specifically developed.

If wave soldering is used the following conditions must be observed for optimal results:

- Use a double-wave soldering method comprising a turbulent wave with high upward pressure followed by a smooth laminar wave.
- For packages with leads on two sides and a pitch (e):
 - larger than or equal to 1.27 mm, the footprint longitudinal axis is **preferred** to be parallel to the transport direction of the printed-circuit board;
 - smaller than 1.27 mm, the footprint longitudinal axis **must** be parallel to the transport direction of the printed-circuit board.

The footprint must incorporate solder thieves at the downstream end.

- For packages with leads on four sides, the footprint must be placed at a 45° angle to the transport direction of the printed-circuit board. The footprint must incorporate solder thieves downstream and at the side corners.

During placement and before soldering, the package must be fixed with a droplet of adhesive. The adhesive can be applied by screen printing, pin transfer or syringe dispensing. The package can be soldered after the adhesive is cured.

Typical dwell time is 4 seconds at 250 °C.

A mildly-activated flux will eliminate the need for removal of corrosive residues in most applications.

12.3.3 MANUAL SOLDERING

Fix the component by first soldering two diagonally-opposite end leads. Use a low voltage (24 V or less) soldering iron applied to the flat part of the lead. Contact time must be limited to 10 seconds at up to 300 °C.

When using a dedicated tool, all other leads can be soldered in one operation within 2 to 5 seconds between 270 and 320 °C.

Stand-alone CAN controller

SJA1000

12.4 Suitability of IC packages for wave, reflow and dipping soldering methods

MOUNTING	PACKAGE	SOLDERING METHOD		
		WAVE	REFLOW ⁽¹⁾	DIPPING
Through-hole mount	DBS, DIP, HDIP, SDIP, SIL	suitable ⁽²⁾	–	suitable
Surface mount	BGA, SQFP	not suitable	suitable	–
	HLQFP, HSQFP, HSOP, HTSSOP, SMS	not suitable ⁽³⁾	suitable	–
	PLCC ⁽⁴⁾ , SO, SOJ	suitable	suitable	–
	LQFP, QFP, TQFP	not recommended ⁽⁴⁾⁽⁵⁾	suitable	–
	SSOP, TSSOP, VSO	not recommended ⁽⁶⁾	suitable	–

Notes

- All surface mount (SMD) packages are moisture sensitive. Depending upon the moisture content, the maximum temperature (with respect to time) and body size of the package, there is a risk that internal or external package cracks may occur due to vaporization of the moisture in them (the so called popcorn effect). For details, refer to the Drypack information in the “*Data Handbook IC26; Integrated Circuit Packages; Section: Packing Methods*”.
- For SDIP packages, the longitudinal axis must be parallel to the transport direction of the printed-circuit board.
- These packages are not suitable for wave soldering as a solder joint between the printed-circuit board and heatsink (at bottom version) can not be achieved, and as solder may stick to the heatsink (on top version).
- If wave soldering is considered, then the package must be placed at a 45° angle to the solder wave direction. The package footprint must incorporate solder thieves downstream and at the side corners.
- Wave soldering is only suitable for LQFP, QFP and TQFP packages with a pitch (e) equal to or larger than 0.8 mm; it is definitely not suitable for packages with a pitch (e) equal to or smaller than 0.65 mm.
- Wave soldering is only suitable for SSOP and TSSOP packages with a pitch (e) equal to or larger than 0.65 mm; it is definitely not suitable for packages with a pitch (e) equal to or smaller than 0.5 mm.

13 DEFINITIONS

Data sheet status	
Objective specification	This data sheet contains target or goal specifications for product development.
Preliminary specification	This data sheet contains preliminary data; supplementary data may be published later.
Product specification	This data sheet contains final product specifications.
Limiting values	
Limiting values given are in accordance with the Absolute Maximum Rating System (IEC 134). Stress above one or more of the limiting values may cause permanent damage to the device. These are stress ratings only and operation of the device at these or at any other conditions above those given in the Characteristics sections of the specification is not implied. Exposure to limiting values for extended periods may affect device reliability.	
Application information	
Where application information is given, it is advisory and does not form part of the specification.	

14 LIFE SUPPORT APPLICATIONS

These products are not designed for use in life support appliances, devices, or systems where malfunction of these products can reasonably be expected to result in personal injury. Philips customers using or selling these products for use in such applications do so at their own risk and agree to fully indemnify Philips for any damages resulting from such improper use or sale.

Stand-alone CAN controller

SJA1000

NOTES

Philips Semiconductors – a worldwide company

Argentina: see South America

Australia: 3 Figtree Drive, HOMEBUSH, NSW 2140,
Tel. +61 2 9704 8141, Fax. +61 2 9704 8139

Austria: Computerstr. 6, A-1101 WIEN, P.O. Box 213,
Tel. +43 1 60 101 1248, Fax. +43 1 60 101 1210

Belarus: Hotel Minsk Business Center, Bld. 3, r. 1211, Volodarski Str. 6,
220050 MINSK, Tel. +375 172 20 0733, Fax. +375 172 20 0773

Belgium: see The Netherlands

Brazil: see South America

Bulgaria: Philips Bulgaria Ltd., Energoproject, 15th floor,
51 James Bourchier Blvd., 1407 SOFIA,
Tel. +359 2 68 9211, Fax. +359 2 68 9102

Canada: PHILIPS SEMICONDUCTORS/COMPONENTS,
Tel. +1 800 234 7381, Fax. +1 800 943 0087

China/Hong Kong: 501 Hong Kong Industrial Technology Centre,
72 Tat Chee Avenue, Kowloon Tong, HONG KONG,
Tel. +852 2319 7888, Fax. +852 2319 7700

Colombia: see South America

Czech Republic: see Austria

Denmark: Sydhavnsgade 23, 1780 COPENHAGEN V,
Tel. +45 33 29 3333, Fax. +45 33 29 3905

Finland: Sinikalliontie 3, FIN-02630 ESPOO,
Tel. +358 9 615 800, Fax. +358 9 6158 0920

France: 51 Rue Carnot, BP317, 92156 SURESNES Cedex,
Tel. +33 1 4099 6161, Fax. +33 1 4099 6427

Germany: Hammerbrookstraße 69, D-20097 HAMBURG,
Tel. +49 40 2353 60, Fax. +49 40 2353 6300

Hungary: see Austria

India: Philips INDIA Ltd, Band Box Building, 2nd floor,
254-D, Dr. Annie Besant Road, Worli, MUMBAI 400 025,
Tel. +91 22 493 8541, Fax. +91 22 493 0966

Indonesia: PT Philips Development Corporation, Semiconductors Division,
Gedung Philips, Jl. Buncit Raya Kav.99-100, JAKARTA 12510,
Tel. +62 21 794 0040 ext. 2501, Fax. +62 21 794 0080

Ireland: Newstead, Clonskeagh, DUBLIN 14,
Tel. +353 1 7640 000, Fax. +353 1 7640 200

Israel: RAPAC Electronics, 7 Kehilat Saloniki St, PO Box 18053,
TEL AVIV 61180, Tel. +972 3 645 0444, Fax. +972 3 649 1007

Italy: PHILIPS SEMICONDUCTORS, Via Casati, 23 - 20052 MONZA (MI),
Tel. +39 039 203 6838, Fax +39 039 203 6800

Japan: Philips Bldg 13-37, Kohnan 2-chome, Minato-ku,
TOKYO 108-8507, Tel. +81 3 3740 5130, Fax. +81 3 3740 5057

Korea: Philips House, 260-199 Itaewon-dong, Yongsan-ku, SEOUL,
Tel. +82 2 709 1412, Fax. +82 2 709 1415

Malaysia: No. 76 Jalan Universiti, 46200 PETALING JAYA, SELANGOR,
Tel. +60 3 750 5214, Fax. +60 3 757 4880

Mexico: 5900 Gateway East, Suite 200, EL PASO, TEXAS 79905,
Tel. +9-5 800 234 7381, Fax +9-5 800 943 0087

Middle East: see Italy

Netherlands: Postbus 90050, 5600 PB EINDHOVEN, Bldg. VB,
Tel. +31 40 27 82785, Fax. +31 40 27 88399

New Zealand: 2 Wagener Place, C.P.O. Box 1041, AUCKLAND,
Tel. +64 9 849 4160, Fax. +64 9 849 7811

Norway: Box 1, Manglerud 0612, OSLO,
Tel. +47 22 74 8000, Fax. +47 22 74 8341

Pakistan: see Singapore

Philippines: Philips Semiconductors Philippines Inc.,
106 Valero St. Salcedo Village, P.O. Box 2108 MCC, MAKATI,
Metro MANILA, Tel. +63 2 816 6380, Fax. +63 2 817 3474

Poland: Al.Jerozolimskie 195 B, 02-222 WARSAW,
Tel. +48 22 5710 000, Fax. +48 22 5710 001

Portugal: see Spain

Romania: see Italy

Russia: Philips Russia, Ul. Usatcheva 35A, 119048 MOSCOW,
Tel. +7 095 755 6918, Fax. +7 095 755 6919

Singapore: Lorong 1, Toa Payoh, SINGAPORE 319762,
Tel. +65 350 2538, Fax. +65 251 6500

Slovakia: see Austria

Slovenia: see Italy

South Africa: S.A. PHILIPS Pty Ltd., 195-215 Main Road Martindale,
2092 JOHANNESBURG, P.O. Box 58088 Newville 2114,
Tel. +27 11 471 5401, Fax. +27 11 471 5398

South America: Al. Vicente Pinzon, 173, 6th floor,
04547-130 SÃO PAULO, SP, Brazil,
Tel. +55 11 821 2333, Fax. +55 11 821 2382

Spain: Balmes 22, 08007 BARCELONA,
Tel. +34 93 301 6312, Fax. +34 93 301 4107

Sweden: Kottbygatan 7, Akalla, S-16485 STOCKHOLM,
Tel. +46 8 5985 2000, Fax. +46 8 5985 2745

Switzerland: Allmendstrasse 140, CH-8027 ZÜRICH,
Tel. +41 1 488 2741 Fax. +41 1 488 3263

Taiwan: Philips Semiconductors, 6F, No. 96, Chien Kuo N. Rd., Sec. 1,
TAIPEI, Taiwan Tel. +886 2 2134 2886, Fax. +886 2 2134 2874

Thailand: PHILIPS ELECTRONICS (THAILAND) Ltd.,
209/2 Sanpavuth-Bangna Road Prakanong, BANGKOK 10260,
Tel. +66 2 745 4090, Fax. +66 2 398 0793

Turkey: Yukari Dudullu, Org. San. Blg., 2.Cad. Nr. 28 81260 Umraniye,
ISTANBUL, Tel. +90 216 522 1500, Fax. +90 216 522 1813

Ukraine: PHILIPS UKRAINE, 4 Patrice Lumumba str., Building B, Floor 7,
252042 KIEV, Tel. +380 44 264 2776, Fax. +380 44 268 0461

United Kingdom: Philips Semiconductors Ltd., 276 Bath Road, Hayes,
MIDDLESEX UB3 5BX, Tel. +44 208 730 5000, Fax. +44 208 754 8421

United States: 811 East Arques Avenue, SUNNYVALE, CA 94088-3409,
Tel. +1 800 234 7381, Fax. +1 800 943 0087

Uruguay: see South America

Vietnam: see Singapore

Yugoslavia: PHILIPS, Trg N. Pasica 5/v, 11000 BEOGRAD,
Tel. +381 11 3341 299, Fax.+381 11 3342 553

For all other countries apply to: Philips Semiconductors,
International Marketing & Sales Communications, Building BE-p, P.O. Box 218,
5600 MD EINDHOVEN, The Netherlands, Fax. +31 40 27 24825

Internet: <http://www.semiconductors.philips.com>

© Philips Electronics N.V. 2000

SCA 69

All rights are reserved. Reproduction in whole or in part is prohibited without the prior written consent of the copyright owner.

The information presented in this document does not form part of any quotation or contract, is believed to be accurate and reliable and may be changed without notice. No liability will be accepted by the publisher for any consequence of its use. Publication thereof does not convey nor imply any license under patent- or other industrial or intellectual property rights.

Printed in The Netherlands

285002/03/pp68

Date of release: 2000 Jan 04

Document order number: 9397 750 06634

Let's make things better.

Philips
Semiconductors



PHILIPS

Mouser Electronics

Authorized Distributor

Click to View Pricing, Inventory, Delivery & Lifecycle Information:

[NXP:](#)

[SJA1000T/N1,112](#) [SJA1000T/N1,118](#)